



Biblical Worldview | Academic Rigor | Critical Thinking | Technology Solutions



# MAKING AN IMPACT

50 YEARS OF SUPPORTING CHRISTIAN EDUCATION

2024 Catalog

**FREE SHIPPING**

[bjupress.com](http://bjupress.com)

# 1974 2024

## IMPACTING GENERATIONS TOGETHER

For fifty years, we have supported Christian educators who shape students' hearts and minds for the path God has prepared for them.

Your dedication to providing an excellent Christian education helps students become lifelong learners and leaders. We are thankful to partner with you as you craft an educational experience that imparts knowledge and shapes lives in both memorable and meaningful ways.



# INTRODUCING

bjupress **trove**<sup>TM</sup>

The premier learning experience platform for teachers and students using BJU Press materials in schools.

## FREE SHIPPING

Free shipping available on all US orders starting February 1, 2024.

## 5% EARLY-BIRD DISCOUNT

We have a special offer for you as you plan your yearly order!

We are extending a 5% discount\* to conventional Christian schools ordering BJU Press educational materials between April 1 and May 31, 2024. Your order will be shipped as soon as possible.

Additionally, you may choose delayed billing\*\* on orders of at least \$1,000 to make your bill due September 1, 2024. Choose "Net September 1" billing to receive this option. Delayed billing is available from April 1, 2024, through July 15, 2024.

BJU Press appreciates this opportunity to serve you. If you have any questions or if we can be of any other assistance, please contact our customer service department at [bjupinfo@bjupress.com](mailto:bjupinfo@bjupress.com) or call 800.845.5731.

\*Does not apply to BJU Press Christian Classroom Online, Trove, DVD options, and Testing & Evaluation orders.

\*\*Does not apply to Testing & Evaluation orders.

# CONTENTS

## 2 New Products

## 4 BJU Press Trove

## 10 Early Childhood

- 13 Pathways for Preschool
- 14 Footsteps for Fours
- 16 Focus on Fives

## 18 Elementary, Middle & High School

- 20 Phonics
- 21 Reading/Literature
- 30 English/Writing & Grammar
- 39 Spelling
- 41 Handwriting
- 42 Vocabulary
- 43 Math
- 52 Science
- 63 Heritage Studies/History
- 72 Bible
- 81 Spanish

## 85 Additional Resources

- 86 Testing & Evaluation

## 88 Additional Technology Resources

- 90 AfterSchoolHelp
- 91 Curriculum Trak
- 92 Christian Classroom Online

## 98 Order Forms

- 101 Textbooks
- 118 Christian Classroom Online

# NEW *for* 2024



## Reading 1

Equips young students to read a variety of genres with fluency, enjoyment, and discernment.

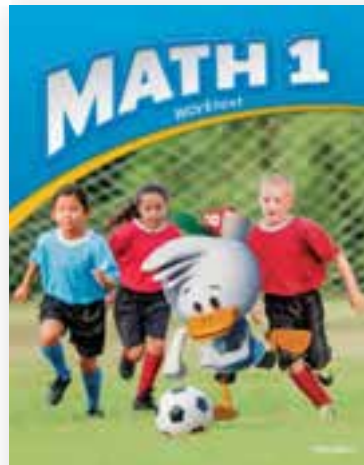

## Math 1

Offers students a biblical foundation in mathematical concepts, skills, and reasoning so that they can solve real-world problems.



## Phonics & English 1

Builds foundational phonics and English skills in young students so they become proficient readers and learn to communicate in considerate ways.

## New Look, Same Content!

*Handwriting 1* and *Spelling 1* have been updated with new visuals for enhanced student experience.



## Handwriting 1

Nurtures foundational handwriting skills in young students so they can begin to express themselves fluently and accurately.



## Spelling 1

Helps students develop foundational spelling skills and recognize spelling as a tool to honor God and to love and serve others through writing.

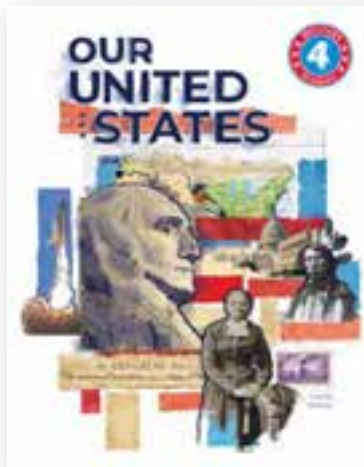

### Heritage 4

Equips students to summarize United States history; analyze regional and state cultures of the United States and its territories; and examine and evaluate actions, decisions, and movements from a biblical worldview.



### Biology

Enables students to ethically engage in biological inquiry and to understand life's design, stability, and protection from a biblical worldview.

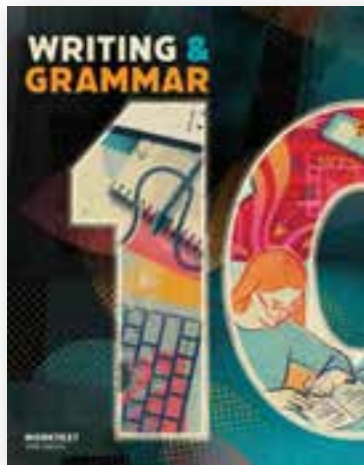

### Writing & Grammar 10

Equips students to apply grammar skills and strategies in writing, speaking, listening, and viewing so they can craft effective communication shaped by a biblical worldview.



### Algebra 1

Equips students to skillfully make and use algebraic models for solving real-world problems.

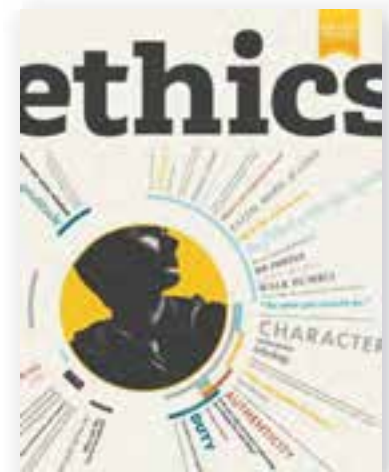

### Bible 12: Ethics

Encourages students to grow in character and biblical thinking so they can make wise ethical choices and defend the Christian faith from a biblical worldview.



**Streamline your workload and engage learners like never before.**

# bjupress **trove**<sup>TM</sup>

**Introducing Trove — the premier learning experience platform for teachers and students using BJU Press materials in schools.**

- **Extensive resource library** with over 40,000 teaching aids for K–12
- **High level of customization** to fit any classroom experience
- **Web-based** for online access anywhere, anytime
- **Easily usable by any school** whether you have limited devices or one device per student
- **User-friendly student portal** that connects learners to eTexts and resources



Learn more at

**[BJUPress.com/technology/Trove](https://BJUPress.com/technology/Trove)**

# Teachers

Building on the best features of our previous technology solutions, Trove makes it easier than ever to find instructional resources, build sharable lesson plans, create digital or printed assessments, and interact with students in an online format.

## Tools for Today's Teachers

### FIND INSTRUCTIONAL RESOURCES

Use **Trove's expansive library of digital resources** to enhance your teaching strategies and free up valuable time. Plus, with **robust search and filter functions** you can quickly locate the materials and assessments you need without all the extra clicking. You can even preview resources without downloading or converting.

### BUILD AND SHARE LESSON PLANS

**Trove's playlist feature** makes lesson planning a breeze. Create playlists and share with co-teachers, administrators, or substitute teachers! Simply select lesson materials from Trove's resource library or add your own, then launch your playlist to seamlessly access all lesson materials during your instruction time.

### CONNECT WITH STUDENTS

Trove allows teacher-student interaction with available digital assessments and eTextbook or eWorktext assignments. Teachers can share BJU Press or teacher created resources with any student who is using BJU Press digital content. Computer-gradable assessments makes grading homework or assessments easy.

### CREATE DIGITAL OR PRINTED ASSESSMENTS

The **Trove assessment builder** gives you the power to customize student assessments and take advantage of autogradability options — saving you grading time and giving students immediate feedback on their performance. Assessments can also be printed out for conventional classroom use.

**Choose from over 70 professional development courses!**





### **Microsoft PowerPoint® presentations**

Pre-designed, **editable Microsoft PowerPoint® presentations** give you a quick starting point.



### **Lesson Plan Overviews**

Plan ahead with editable **Microsoft Word® lesson plan overviews** of each day's objectives, content, and needed materials. Use **BJU Press curriculum map PDFs** to help prepare your own curriculum maps.



### **Media**

**Video and audio segments** provide enrichment for your lessons, allowing you to customize your instruction and engage your students.



### **Additional Resources**

**Instructional aids, weblinks, maps, charts, games, artwork, answer keys, and more** are all available to support you as you present lessons, reach struggling learners, and challenge all students in their learning.



### **Assessments**

**Trove's assessment feature** allows you to use a bank of questions to create customized quizzes and tests for print or online use. You can edit questions and answers and easily create multiple versions of tests to discourage cheating.



### **eTexts**

Access **BJU Press teacher and student eTexts and eWorktexts** anywhere, on any device. Includes offline availability.



### **Professional Development**

Over **70 free workshops** give you tools to keep growing as an educator.

# Students

Trove offers your students the convenience of accessing BJU Press materials, class resources, and assessments online from any device, anywhere.

## Connection for Today's Students

- **Simple, easy-to-use portal** created with students in mind.
- With **eTextbooks and eWorktexts** students can read, take notes, and even complete assignments all within Trove. **Text-to-speech and improved accessibility** features come with each eText, and mobile apps with downloading features provide offline learning options.
- Students can receive **content, assignments, and assessments** from teachers.
- Students can easily complete assessments within Trove. **Autogradable assessment features** give students immediate feedback on their work.

You can project resources or individually share them with students who have Trove access.



# Get Trove for Teachers

An **Annual Trove School Site License\*** gives all teachers at your school access to the Trove teacher resources, including eText copies of student and teacher editions.



## Add Trove for Students

**Students can now access eTextbooks or eWorktexts\*** through the Trove platform. New, affordable bundled pricing makes both print and digital access options possible, so teachers and students can benefit from the full digital experience.

\*See page 101 for pricing.

## New in 2024



Visit our website to sign up for exclusive updates.



## Early Childhood

BJU Press early childhood materials leverage strategic play in the context of preschool, K4, and K5 instruction to build foundational skills for elementary school. We have designed each level to gradually prepare young learners with the foundations they will need for future education. We use songs, games, and characters to introduce students to phonics skills, numbers, shapes, letters, colors, and more.







# Early Childhood

**BJU Press's early childhood program** develops foundational knowledge and skills in Bible, math, social studies, science, handwriting, and language arts for future grades. This program, flexible for all types of learners at all stages of learning, develops the joy of learning through both teacher-guided and independent discovery-based activities. Daily themed lessons teach foundational skills that are supported with music and engaging visuals. Free play at intentional learning centers encourages natural curiosity, while group activities encourage social-emotional development. Biblical worldview themes point students to a knowledge of God and His will.

## Vision

To enable students to develop foundational knowledge and skills through guided activities and independent exploration that leads to the joy of learning and an ability to relate biblically to their authorities and peers.

## Goals

- To teach students foundational phonics to prepare for reading with understanding
- To guide students to apply foundational Bible, math, science, and social studies skills
- To give students opportunities to communicate through listening, speaking, and composing
- To guide students to relate biblically to their fellow students, authorities, and other people in their communities
- To provide students with opportunities for hands-on learning, discovery learning, and intentional play
- To equip students to apply the knowledge of God to how they think, learn, and play



# EARLY CHILDHOOD Pathways for Preschool



Gather two- and three-year-olds for circle time at the Big Red Barn! New animal friends will introduce learning through play with songs, rhymes, games, crafts, snacks, stories, learning activities, and much more. This research-based, developmentally appropriate program prepares students for future learning, using activities and games that encourage phonemic awareness and letter and number recognition.

## Instructional Materials

### Teacher Edition

This teacher edition provides a flexible format for a 2-to-5-days-per-week schedule for 9 to 12 months per year. With an emphasis on interaction, play, and experiences, the teacher edition allows flexibility while providing a structure to systematically work through skills in an organized and purposeful way. The book includes activities that promote prereading skills with phonemic awareness and letter recognition. It also includes math, social studies, and science segments as well as optional advanced segments for math and phonics.

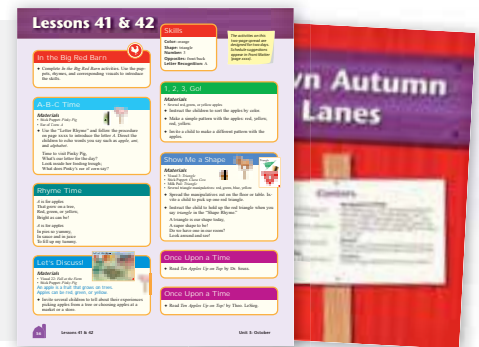

### Teaching Visuals

The teaching visuals packet includes engaging charts that are big enough for children to see yet easy for teachers to handle. These charts and visuals introduce themes, shapes, colors, numbers, letters, and nursery rhymes. Colorful shape manipulatives may be punched out to help children understand pre-math concepts, such as counting, sorting, and patterning. This packet also includes the pieces to create the interactive Big Red Barn used in circle time. These materials are now available on Trove.

### Pricing

For Teachers	
<b>Teacher Edition</b>	<b>88.50</b>
<b>Visuals</b>	<b>86.75</b>
Hoppy Tunes CD	39.00
For Students	
<b>Activity Packet</b>	<b>31.00</b>

### Activity Packet

The activity packet contains theme-related pages of activities and crafts. Children learn to trace, match, cut, and color to reinforce the skills and concepts from the lessons. Three pages of stickers add to the fun.

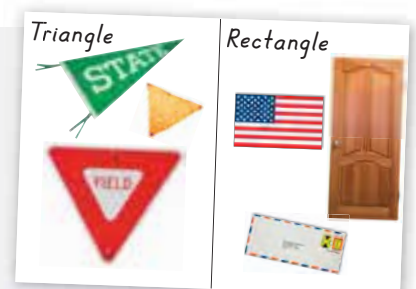



## EARLY CHILDHOOD

# Footsteps for Fours

Max and his animal friends bring four-year-olds to the Teaching Tree for more learning opportunities! Young learners explore foundational math, phonics, and prereading skills with their teacher and each character. Interactive lessons introduce music, science, language arts, social studies, and handwriting on an age-appropriate level. Learn more at [bjupress.com/category/k4-footsteps-for-fours-curriculum](http://bjupress.com/category/k4-footsteps-for-fours-curriculum)



### Additional Subject

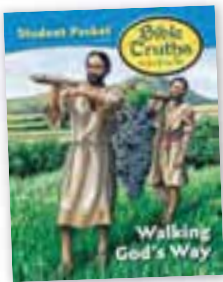

#### K4 Bible: Walking God's Way

Illustrate godly character traits with stories from the Old and New Testaments as well as modern-day application stories. Each of the 165 teaching cards features full-color, realistic artwork on the front and teaching instructions on the back. An additional student packet offers learning activities and practice opportunities.

### BJU Press Trove™ Teacher Resources

Get your early learners busy with a wealth of digital resources to help keep them engaged and motivated for learning! Trove offers visuals, digital teacher editions, instructional aids, lesson plan overviews, and curriculum maps for all preschool and kindergarten programs, except K4 Bible. For Footsteps for Fours, Focus on Fives, and Math K5, you have access to editable Microsoft PowerPoints® slides to introduce new concepts with colorful visuals and embedded audio and video and help you save time in preparing.

Trove Microsoft PowerPoint® slides aren't in detailed outline style. Instead, each presentation is short enough for students to stay engaged and is full of fun visuals and audio and video selections.

See pages 4–9 for more information on BJU Press Trove and availability information.





## Instructional Materials

### Teacher Edition

This four-volume teacher edition includes daily lessons and suggested activities to set up each interactive learning experience and begin biblical worldview shaping. Lessons incorporate prereading skills with phonemic awareness and phonics, math, handwriting, social studies, and science activities.

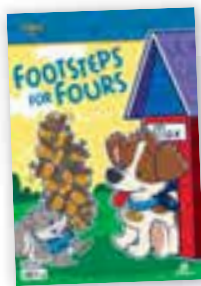
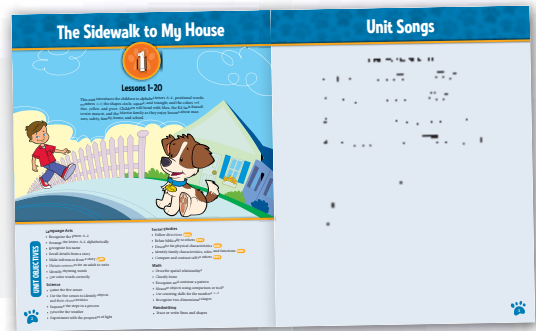

### Interactive Learning Materials

This visual and hands-on program includes teaching visuals, the Teaching Tree and phonics charts, a puppet, backpack, and fifty practice cards with letters, numbers, shapes, and colors.

### Practice Packets

The activity and writing packets reinforce skills introduced in each lesson, giving students practice opportunities to develop crucial learning skills, such as hand-eye coordination, fine motor and handwriting skills, reading left to right, alphabetizing, and number order. Teachers can also use these packets as formative or summative assessments.

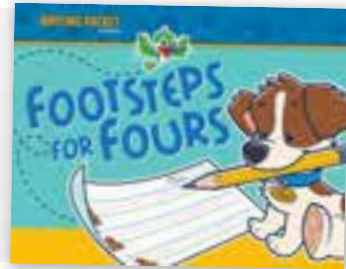

### Audio Files

Audio files are available with theme-related songs and listening selections on Trove.

### BJU Press Trove™

Trove provides teachers with a wealth of premium resources that expedite lesson planning and encourage interactivity in the classroom. For more information, see pages 4–9.

## Pricing

### Bible Truths for Early Childhood (2nd Edition)

For Teachers

<b>Teaching Cards (165 picture cards with lesson on back) &amp; Teacher's Guide</b>	<b>168.25</b>
Music CD	22.75

For Students

<b>Student Packet</b>	<b>41.75</b>
-----------------------	--------------

Essential items are in bold.



### Footsteps for Fours (3rd Edition)

For Teachers

<b>Teacher Edition, Backpack &amp; Hand Puppet</b>	<b>210.50</b>
Teacher Edition	163.75
<b>Visuals</b>	<b>76.00</b>
<b>Phonics Charts</b>	<b>76.00</b>
<b>Teaching Tree</b>	<b>29.25</b>

For Students

<b>Activity Packet</b>	<b>41.75</b>
<b>Writing Packet</b>	<b>34.50</b>
<b>Practice Cards</b>	<b>15.75</b>



## EARLY CHILDHOOD

# Focus on Fives



Hopscotch is eager to bounce into kindergarten learning with five-year-olds! This journey is all about preparing children with the skills they will need for first grade. Hopscotch and his other friends will introduce young learners to science, heritage studies, handwriting, phonics, and reading. Daily learning activities help students build a foundation in phonemic awareness, reading strategies, listening, and speaking. Learn more at [bjupress.com/category/k5-beginnings-curriculum](http://bjupress.com/category/k5-beginnings-curriculum)



## Pricing

For Teachers

<b>Teacher Edition (6 vols.)</b>	<b>159.00</b>
<b>Phonics Charts</b>	<b>86.75</b>
<b>Visuals</b>	<b>80.25</b>

For Students

<b>Student Worktext</b>	<b>41.75</b>
<b>Reading Books for K5 (34 books)</b>	<b>60.25</b>
<b>Phonics Practice for K5</b>	<b>29.25</b>
<b>Phonics &amp; Review Cards</b>	<b>12.75</b>
Write Now! Handwriting	11.00
<i>Up the Ladder</i> (10 supplemental readers)	12.60
<i>The Starting Line</i> (12 storybooks)	18.00

**Essential items are in bold.**

For K5 Math, see pages 17 and 45.  
For K5 Bible, see pages 17 and 74.

bjupress **trove**<sup>™</sup>  
Content available on BJU Press Trove

# Instructional Materials

## Teacher Edition

This six-volume teacher edition offers activities to engage early learners in 180 developmentally appropriate lessons. It includes activities and strategies for using the 34 reading books and teaching skills in language, science, social studies, art, and more. The instructional materials begin worldview shaping by encouraging students to apply the course’s key biblical worldview themes.

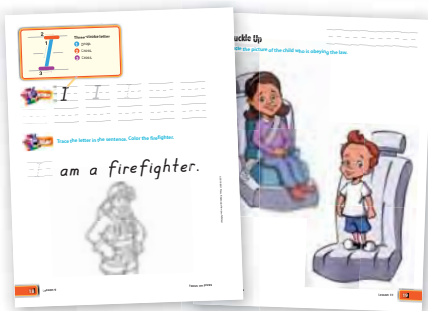
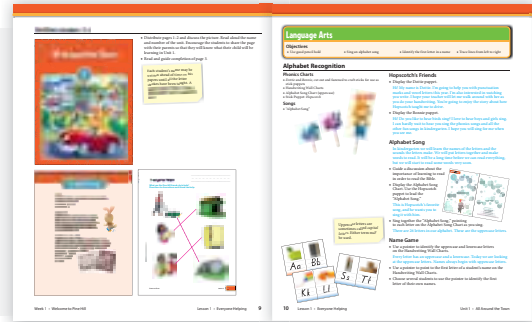

## Worktext and Readers

The worktext provides opportunities for practice and assessment for science, social studies, phonics, reading, and handwriting. Weekly evaluation pages and additional pages at the end of each unit track students’ progress. The 34 reading books help develop word recognition and other early reading skills.

## Visual Learning Materials

Phonics charts, phonics and review cards, and a visuals packet give teachers resources for interactive, engaging lessons.



## Practice Packets

The Phonics Practice and Write Now! Handwriting packets reinforce skills introduced in each lesson, giving students practice opportunities to develop crucial learning skills.



## Audio Files

Audio files are available with theme-related songs and listening selections on Trove.

## BJU Press Trove™

Trove provides teachers with a wealth of premium resources that expedite lesson planning and encourage interactivity in the classroom. For more information, see pages 4–9.

## Additional Subjects



### K5 Math

Cheddar and Farmer and Mrs. Brown explore the world of numbers together! Each lesson uses manipulatives to build number sense and other early math skills. Learn more on pages 43–45.



### K5 Bible: Exploring God’s Word

Introduce your early learners to basic Bible literacy through engaging story cards that help them understand the storyline of Scripture. Learn more on pages 72–74.



## Elementary, Middle & High School

Our full range of student and teacher materials cover all core academic disciplines for Grades 1 through 12. We also provide materials for Bible and foreign language electives. In alignment with our standards for biblical worldview shaping and excellence, all our materials have been written according to biblical worldview foundations and incorporate research on best practices in teaching. Together, our materials equip teachers with abundant resources for developing knowledge and skills, engaging students, planning effective lessons, using different teaching strategies, and assessing students' development.







# Phonics

**BJU Press's systematic and explicit phonics instruction** equips students to comprehend text and become fluent readers, as well as readers of the Bible. Phonics instruction includes phonemic awareness strategies as well as phonics practice using phonics stories and characters, phonics songs, rhyming songs, read-alouds, and multisensory activities that combine letters and sounds into real words. Word families provide the basis for phonics instruction, correlating phonics with reading and spelling instruction as well as writing and grammar. Phonics instruction covers short and long vowels, consonant blends, digraphs, *r*-influenced vowels, special vowel sounds, silent consonants, suffixes, and syllable division.

*More information on Phonics & English 1 products and pricing is on page 32. More information on Reading 1 products and pricing is on page 23. More information on Spelling 1 products and pricing is on page 40.*

## Vision

To equip students to make meaning from print through phonics instruction, to read with understanding and fluency, to communicate effectively, and to enjoy lifelong reading.

## Goals

- To cultivate reading readiness and spelling consciousness through phonemic awareness
- To teach a phonics approach to reading through systematic, explicit, and multisensory instruction
- To develop decoding skills through application of phonics
- To build vocabulary to improve reading comprehension through context
- To promote fluency through silent and oral practice to ensure accuracy and automaticity
- To equip students to read the Bible and develop a biblical worldview

Phonemic awareness and early phonics skills are first introduced in Pathways for Preschool and Footsteps for Fours. These concepts are then explicitly taught in Focus on Fives, Phonics & English 1, and Reading 1 and 2. Our Reading 3 and elementary Spelling courses also review and reinforce these skills. Please see each subject's respective page for details about necessary materials and technology.





**BJU Press's elementary reading product line** develops student literacy by focusing on literary skills and comprehension strategies. Students build on the phonics foundation laid in the early grades, reading texts of increasing complexity in a variety of genres. Students develop their communication skills through oral and silent reading, responsive writing, and oral presentations. Using the before, during, and after reading process, students learn literary terms, reading strategies, and vocabulary words and learn to evaluate all that they read from a biblical worldview.

## Vision

To equip students to enjoy lifelong reading, to analyze and interpret texts in a variety of genres, to evaluate all that they read from a biblical worldview, and to become effective communicators.

## Goals

- To foster the joy of reading
- To differentiate instruction with reading groups to meet the instructional needs of individual students
- To integrate a systematic phonics approach to decoding and word-work instruction
- To teach vocabulary in context
- To promote fluency through silent and oral practice to ensure accuracy and automaticity
- To enhance comprehension through knowledge-building selections
- To develop discernment by evaluating literature from a biblical worldview

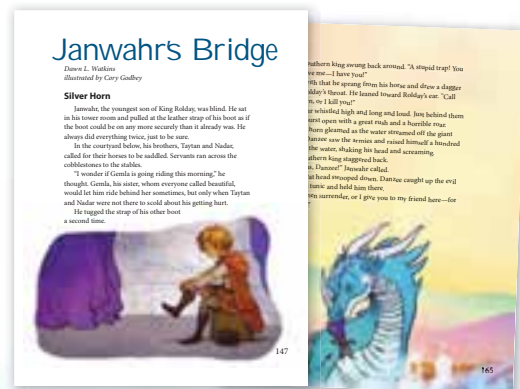



## Instructional Materials

### Student Edition (eStudent Edition Available)

Each reading book offers engaging, age-appropriate selections from a variety of genres to encourage reading success in every student. To make selections more accessible, we have separated the student text into multiple volumes in primary grades.

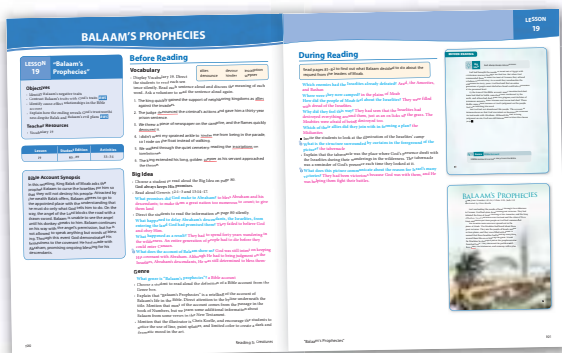

### Teacher Edition

Each teacher edition includes lesson guides that encourage comprehension and fluency in silent and oral reading. Teachers will find resources for shaping a biblical worldview and building critical thinking skills through teacher-led discussions and activities. Additional resources encourage teacher-modeling as students create book reports and practice reading strategies.

### Worktext (eWorktext Available)

The worktext offers practice and assessment opportunities to apply comprehension, critical thinking, and literary skills.

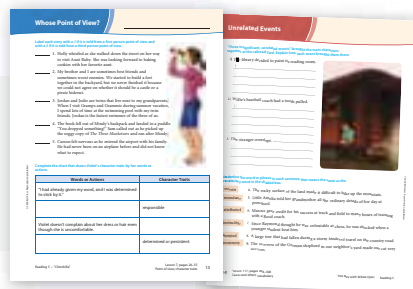

### Assessments

Assessment packets include grade-level-appropriate selections in a variety of genres. Questions about the selections assess the students' reading comprehension and vocabulary skills and prepare them for standardized testing. Reproducible assessments are included with teacher edition purchases for Grades 1–3. Standardized-testing formatted packets are available for purchase for Grades 4–5. Print and digital formats are available.



### Novel Studies

Teaching guides for integrated novel studies are included either as BJ Booklink guides (Grades 2–3) or as a volume of the teacher edition (Grades 1, 4, and 5). Additional novel studies for Grades 1–5 are available on pages 85 and 113.



# Course Overview

The chart below is a summary of the content covered in our elementary reading program. For a more detailed description of content covered in each grade, visit [bjupress.com/scope/reading](http://bjupress.com/scope/reading)

## Novels (student copies sold separately)

	<p><b>Reading 1: Travels Together</b></p> <p>Equips young students to read a variety of genres with fluency, enjoyment, and discernment; teaches students phonemic awareness, vocabulary, fluency, and comprehension; helps students apply various reading strategies and skills to age-appropriate stories and poems.</p> <p><i>See Phonics &amp; English 1 and Spelling 1 for a complete phonics package.</i></p>	<ul style="list-style-type: none"> <li>• <i>The Bravest Dog Ever: The True Story of Balto</i></li> </ul>
	<p><b>Reading 2</b></p> <p>Provides interesting biblical-worldview-shaping selections from a variety of genres that have been logically sequenced for readability and skill progression to help all students succeed; emphasizes silent reading for comprehension, development of higher-order thinking skills, and instruction in phonics, oral reading, and literary techniques.</p>	<ul style="list-style-type: none"> <li>• <i>The Treasure of Pelican Cove</i></li> <li>• <i>Pulling Together</i></li> </ul>
	<p><b>Adventures in Reading 3</b></p> <p>Provides biblical-worldview-shaping selections from a variety of genres that progress in difficulty to promote success for all students; builds on comprehension and critical thinking while expanding literary skills through group activities and discussion.</p>	<ul style="list-style-type: none"> <li>• <i>The Case of the Dognapped Cat</i></li> <li>• <i>These Are My People</i></li> </ul>
	<p><b>Reading 4: Voyages</b></p> <p>Guides students to lifelong reading success by teaching biblical discernment through teacher-guided instruction; develops comprehension through strategies, questions, and activities before, during, and after reading.</p>	<ul style="list-style-type: none"> <li>• <i>Sarah, Plain and Tall</i></li> <li>• <i>Medallion</i></li> <li>• <i>The Lion, the Witch and the Wardrobe</i></li> </ul>
	<p><b>Reading 5: Quests</b></p> <p>Prepares students for the increased academic demands of the future with contemporary and classical literary selections and activities that blend research and literary skills.</p>	<ul style="list-style-type: none"> <li>• <i>Misty of Chincoteague</i></li> <li>• <i>Brady</i></li> <li>• <i>The Horse and His Boy</i></li> </ul>

## Pricing

For Teachers

<b>Teacher Edition Set</b>	<b>85.25–96.00</b>
<b>Worktext Answer Key</b>	<b>22.75–39.00</b>
<b>Assessments Answer Key (Grades 4–5)</b>	<b>12.75</b>
Assessments & Answer Key	13.00
Phonics Review Answer Key (Grades 2–3)	31.00

For Students

<b>Student Edition</b>	<b>22.25–80.25</b>
eStudent Edition	11.75–42.25
<b>Worktext</b>	<b>22.75–39.00</b>
eWorktext	22.75–39.00
<b>Novel</b>	<b>6.29–8.99</b>
<b>Printed Assessments (Grades 4–5)</b>	<b>6.88</b>
eAssessments (Grades 4–5)	6.88
Phonics Review (Grades 2–3)	29.25

Essential items are in bold.

bjupress **trove**<sup>™</sup>  
Content available on BJU Press Trove



# Technology Resources

## BJU Press Trove™ Teacher Resources

Help grow your students' love for reading with a wealth of age-appropriate tools and resources. A Trove subscription includes access to:

- Short video segments that will help engage students as you introduce phonics and vocabulary, new reading comprehension and literary concepts, and even special assignments.
- Editable Microsoft PowerPoint® slides containing appealing visuals, thought-provoking discussion questions, engaging reviews, and more, to aid in quick lesson preparation and students' visual engagement.
- Student eTextbooks to project reading selections for lesson discussions or read-alouds.

See pages 4–9 for more information on BJU Press Trove and availability information.





## Middle School

BJU Press's middle school literature product line offers an enriching literary experience that promotes an appreciation of notable literature and encourages critical thinking. Students use close-reading strategies to engage with a variety of texts from diverse authors and genres, analyzing author's craft, identifying themes, and interpreting meaning. Through before, during, and after reading instruction, students evaluate literary texts and connect text to text, text to self, and text to the world, all within the context of a biblical worldview.

## Vision

To analyze and evaluate texts in a variety of genres in order to cultivate lifelong readers and creative communicators and to formulate a biblical worldview.

## Goals

- To expose students to a wide variety of notable literature from across different cultures and time periods
- To model a variety of reading comprehension strategies
- To guide students to analyze, interpret, and evaluate the central themes and ideas that appear in literary and informational texts
- To develop student writing skills, leading them through the writing process to narrate, inform, argue, or persuade
- To support writing by citing textual evidence
- To encourage vocabulary development through context and domain-specific instruction
- To compare and contrast texts in a variety of genres and disciplines
- To guide students to interpret and evaluate images and relate them to literary texts through visual analysis
- To support 21st century skills through collaborative and individual communication, drawing on textual models and technological skills
- To develop discernment by evaluating texts from a biblical worldview



## High School

**BJU Press's secondary literature** helps students go beyond learning about literature to learning how to interact with literature. Students develop a deeper understanding of their fellow man as they examine texts from different cultures, diverse authors and genres, and a range of time periods. Students use text-focused close reading techniques through a before, during, and after reading approach which emphasizes comprehension and critical thinking. Students evaluate each selection, sharpening their discernment and shaping their worldview.

## Vision

To develop discerning, lifelong readers and creative communicators through the independent analysis and evaluation of historical and contemporary literature in a variety of genres.

## Goals

- To develop cultural and historical literacy that will illuminate the study of literature and informational texts
- To teach a variety of reading strategies and literary skills to help students comprehend, compare, analyze, interpret, evaluate, and create literary texts
- To develop vocabulary acquisition through context and domain-specific instruction
- To offer a broad range of reading opportunities using engaging selections from classic and contemporary literature
- To guide students to interpret and evaluate images and relate them to literary texts through visual analysis
- To engage students in approaching real-world questions from a biblical worldview, leading them to exercise discernment and to formulate biblical responses to the issues raised by their reading
- To provide opportunities for individual and collaborative communication, drawing on textual models and technology skills





## Instructional Materials

### Student Edition (eStudent Edition Available)

Student editions will introduce students to major writers from many different cultures and to foundational terms and concepts for literary criticism. Each selection will encourage them to follow the before, during, and after reading process, and informative sections and discussion questions help them analyze a work's elements and theme, evaluate its literary merit, and view its message from a biblical worldview.

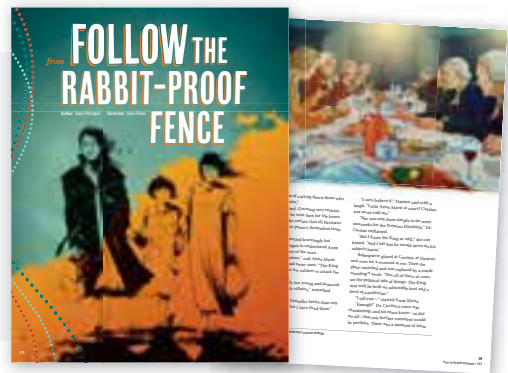

### Teacher Edition

Teacher editions include reduced-sized student pages with margin notes with lesson content, teaching strategies, guides, discussion questions, optional activities, literary analysis ideas, worldview evaluation prompts, and much more.

### Assessments

Assessment packets include grade-level-appropriate summative assessments for each unit, and a final exam in Grade 7 and above. Print and digital formats are available. Test bank questions, available with a Trove subscription, are used to create custom print and digital assessments for BJU Press materials. Additional assessment resources are available and vary by grade level.



# Course Overview

The chart below is a summary of the content covered in our literature program. For a more detailed description of content covered in each course, visit [bjupress.com/scope/literature](http://bjupress.com/scope/literature)

## Novels

	<p><b>Perspectives in Literature (6)</b> Offers a variety of selections and reading strategies to encourage and guide students in reading both literary and informational texts. Writing opportunities encourage students to think critically and apply worldview shaping to the selections they read.</p>	<ul style="list-style-type: none"> <li>• <i>The Book of Three</i></li> <li>• <i>A Single Shard</i></li> <li>• <i>Island of the Blue Dolphins</i></li> </ul>
	<p><b>Exploring Themes in Literature (7)</b> Introduces students to intensive critical reading of various genres with the reading process approach. It addresses six themes in literature and explores literary terms, reading strategies, and processes for analysis and appreciation.</p>	<ul style="list-style-type: none"> <li>• <i>The Last Battle</i></li> </ul>
	<p><b>Making Connections in Literature (8)</b> Equips students with the reading strategies and literary skills they need to comprehend, analyze, interpret, and compare texts of various genres. Students will use the reading process approach throughout to evaluate contemporary and classic selections to develop both artistic and biblical discernment.</p>	<ul style="list-style-type: none"> <li>• <i>Across Five Aprils</i></li> </ul>
	<p><b>Fundamentals of Literature (9)</b> Emphasizes analysis of six central components of literature through a literary-critical approach. Units focus on central themes in selections from three main genres.</p>	
	<p><b>Elements of Literature (10)</b> Explores and analyzes six elements and six genres of literary writing through a literary-critical approach. Units cover selections from a variety of world cultures as well as Shakespeare's <i>Romeo and Juliet</i>.</p>	
	<p><b>American Literature (11)</b> Discusses the five periods of American literature from Native American and colonial literature to contemporary literature using the reading process approach. It challenges students' skills of analysis and evaluation.</p>	
	<p><b>British Literature (12)</b> Discusses the five literary periods of British literature from the Middle Ages to modern and contemporary literature using the reading process approach. Students explore the problem of the human condition as it occurs in literature.</p>	

## Pricing

For Teachers

<b>Teacher Edition</b>	<b>84.50</b>
<b>Activities Answer Key (Grade 6)</b>	<b>39.00</b>
<b>Assessments Answer Key</b>	<b>13.75</b>

For Students

<b>Student Edition</b>	<b>68.00</b>
eStudent Edition	35.75
<b>Activities (Grade 6)</b>	<b>39.00</b>
eActivities	39.00
<b>Printed Assessments</b>	<b>7.39</b>
eAssessments	7.39

Essential items are in bold.



# MIDDLE & HIGH SCHOOL | Literature

## Technology Resources

### BJU Press Trove™ Teacher Resources

Deepen your students' reading comprehension with extra resources that you can use to encourage engagement and add opportunities to your lessons.

- Short video segments introduce new authors, literary terms or concepts, activities, and assignments.
- Editable Microsoft PowerPoint® slides include reviews, vocabulary, new lesson concepts, and discussion questions to help students engage in the reading process approach, guiding them through before, during, and after reading activities.
- To analyze literary works together as a class, access eTextbooks to project selections.
- Trove's assessment feature allows you to create customized quizzes and tests using a bank of questions that correlate with each unit. You can edit questions and answers and easily create multiple versions of tests to discourage cheating.

See pages 4–9 for more information on BJU Press Trove and availability information.





# ELEMENTARY English

**BJU Press's elementary English writing and grammar product line** connects writing, mechanics, listening, speaking, and viewing together to provide students with a solid English language arts foundation. Students study one part of speech at a time, mastering English conventions through spiral review and ample practice of each skill. Proofreading activities give students practice in analyzing sentences, identifying grammatical errors, and correcting errors within the context of writing. Students follow the writing process to write opinion pieces, informational texts, and narratives. Students develop their craft through teacher modeling and student collaboration as they write in various genres for real-world contexts.

## Vision

To equip students to master foundational grammar and writing skills to craft effective written and oral communication that serves others.



## Goals

- To foster an appreciation of language as a gift from God
- To develop a foundational knowledge of English grammar and mechanics
- To develop study and reference skills
- To teach the writing process for narrative, informative, opinion, and expository writing
- To encourage clear and effective writing through mentor text analysis and regular practice of writing in real-world contexts
- To develop technological literacy through publishing
- To guide the development of collaboration, listening, speaking, and viewing skills
- To provide space for reflection on communication that serves others

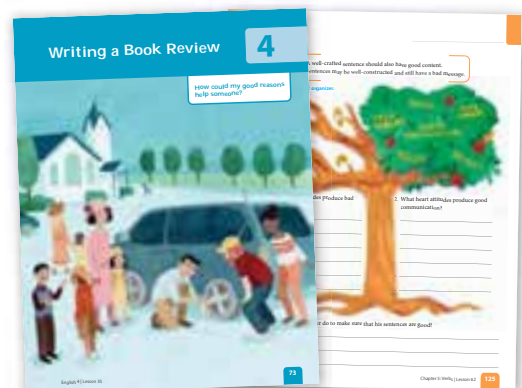





## Instructional Materials

### Worktext (eWorktexts Available)

These worktexts teach traditional grammar through teacher and mentor text modeling as well as independent practice. Students learn writing skills across many genres through the five steps of the writing process. Chapter reviews and cumulative reviews provide a spiral review of skills. Each worktext also contains a writing handbook with a thesaurus, charts for student reference, and more.

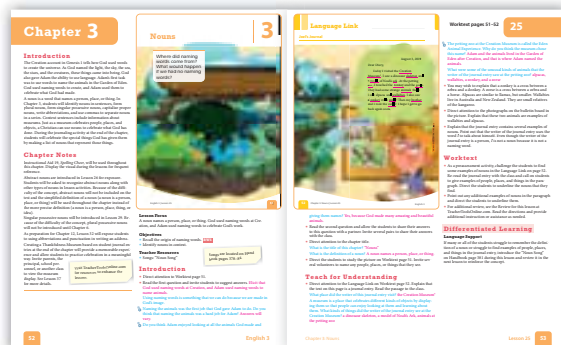
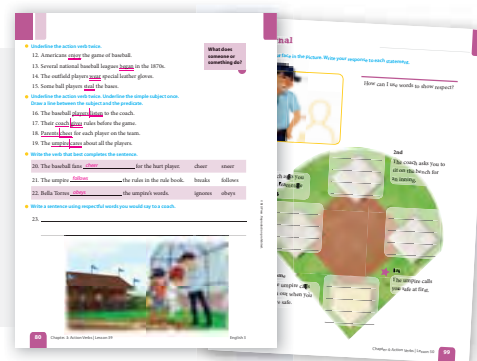

### Teacher Edition

The teacher editions provide a thorough presentation of English instruction with a balance of grammar study and writing practice. These editions provide easy instructions for teaching grammar and writing using the writing process. Suggestions for working with ELL students appear throughout the material. Discussions and activities develop students' critical thinking and biblical worldview.

### Assessments

Assessment packets include age-appropriate and grade-level summative assessments of grammar concepts. Each assessment aligns with the stated objective available in the teacher edition. Print and digital formats are available. Rubrics for writing assignments are available on Trove and with the Instructional Aids in the teacher edition.



# Course Overview

This chart highlights the content covered in our elementary English program. Students develop skills in identifying parts of speech, recognizing sentence patterns, proofreading, using the writing process, and using reference materials. For a more detailed description of content covered in each grade, visit [bjupress.com/scope/english](http://bjupress.com/scope/english)

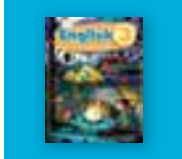
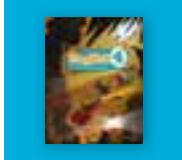
	Grammar, Usage, and Mechanics	Writing Projects
	<ul style="list-style-type: none"> <li>Builds foundational phonics and English skills in young students so they become proficient readers and learn to communicate in considerate ways.</li> <li>Helps students recognize and articulate sounds, develop listening and speaking skills, and apply biblical worldview themes to discussion on loving God, being helpful, showing courage, and more.</li> </ul> <p><i>See Reading 1 and Spelling 1 for a complete phonics package.</i></p>	Paragraph, informative paragraph, personal story, couplet, thank-you note, opinion paragraph, biographical paragraph
	<ul style="list-style-type: none"> <li>Encourages understanding of subjects and verbs in a communicative context.</li> <li>Teaches simple sentences and paragraphs.</li> <li>Introduces capitalization and punctuation conventions as well as proper usage.</li> </ul>	Personal narrative, instructions, couplet, shape poem, friendly letter, opinion paragraph, research report
	<ul style="list-style-type: none"> <li>Expands understanding of the parts of speech.</li> <li>Provides a foundation for sentence variety and structure.</li> <li>Explores different types of pronouns.</li> </ul>	Game instructions, friendly letter with personal narrative, persuasive essay, book review, sound poem, research report
	<ul style="list-style-type: none"> <li>Develops understanding of adjectives and adverbs.</li> <li>Encourages development of digital and visual literacy, critical thinking, and collaboration.</li> <li>Explores common usage problems.</li> </ul>	Compare/contrast essay, book review, tall tale, research report, writing a story, acrostic poem
	<ul style="list-style-type: none"> <li>Applies English conventions to oral and written communication.</li> <li>Develops skills in digital and visual literacy.</li> <li>Uses collaboration and research skills to enhance the writing process.</li> <li>Helps students present ideas in spoken, written, and visual forms.</li> <li>Applies biblical worldview themes in communication.</li> </ul>	Diamante, sense poem, book review, compare/contrast essay, persuasive letter, personal narrative, research report

## Pricing

For Teachers

<b>Teacher Edition</b>	<b>80.25–97.75</b>
<b>Assessments Answer Key</b>	<b>12.75</b>

For Students

<b>Student Worktext</b>	<b>32.50–39.00</b>
eWorktext	32.50–39.00
<b>Printed Assessments</b>	<b>6.88</b>
eAssessments	6.88

Essential items are in bold.



AfterSchoolHelp

Content available on BJU Press Trove



# Technology Resources

## BJU Press Trove™ Teacher Resources

Teach writing and grammar with a wealth of age-appropriate resources to engage students.

- Video segments introduce grammar concepts and rules, teach and review phonics skills, and introduce writing assignments.
- Editable Microsoft PowerPoint® slides walk through grammar concepts, activities, and the writing process, supporting you in providing teacher demonstrations and exploring mentor texts.
- For English 4–5, Trove’s assessment feature allows you to create customized quizzes and tests using a bank of questions that correlate with each chapter.

See pages 4–9 for more information on BJU Press Trove and availability information.

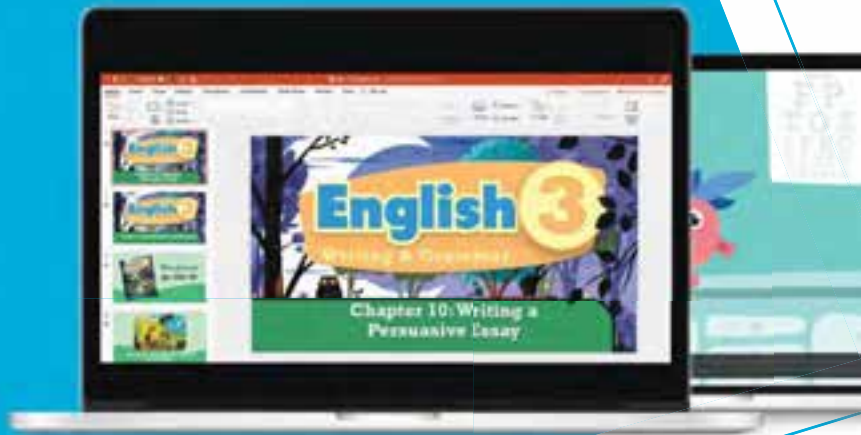

## AfterSchoolHelp

Do your students need extra grammar practice? AfterSchoolHelp.com is a free digital tutor with short video lessons and practice segments for English 4 and English 5 students.



# MIDDLE & HIGH Writing & Grammar

## Middle School

**BJU Press's middle school writing and grammar product line** provides students with practice and review of grammar and mechanics skills and application of those skills to writing. Students hone their argumentative, informative, and narrative writing skills, creating written works in writing workshops. Collaborative activities and projects give students opportunities to improve their researching, writing, speaking, and listening skills. Presentations develop technological and multimedia skills. Students develop a biblical worldview that informs communication.

## Vision

To equip students to apply grammar and writing skills to craft effective written and oral communication from a biblical understanding of discernment and integrity.

## Goals

- To ensure mastery of English grammar and mechanics
- To relate mentor texts to grammar instruction and writing activities
- To provide regular opportunities to practice the writing process with genre-specific writing strategies
- To encourage students to develop a writing style that communicates a unique voice
- To help students develop study, reference, and research skills, effectively using print and digital sources
- To provide opportunities to collect, synthesize, and evaluate information
- To guide students to communicate effectively in a variety of modes and genres, considering audience and purpose from a biblical worldview



# High School

**BJU Press's secondary writing and grammar product line** provides students with a real-world focus for exercising language skills as they systematically review and practice grammar and mechanics with increasing complexity. Activities give students practice in analyzing, combining, and drafting text in various genres. Students synthesize grammar, usage, research, writing, digital, speaking, and listening skills to become effective oral and written communicators.

## Vision

To equip students to apply grammar and writing skills to craft effective written and oral communication that engages with and contributes to culture.

## Goals

- To ensure mastery of English grammar and mechanics
- To develop students' mastery of study, reference, and research skills, effectively using print and digital sources
- To model the connection of mentor texts to grammar instruction and writing activities
- To give opportunities for students to use the writing process with genre-specific strategies to craft communication for real-world contexts
- To guide students to hone collaboration, listening, speaking, and viewing skills
- To expand technological and media literacy through written, oral, and visual communication
- To lead students to draft writing that is truthful, virtuous, and empathetic

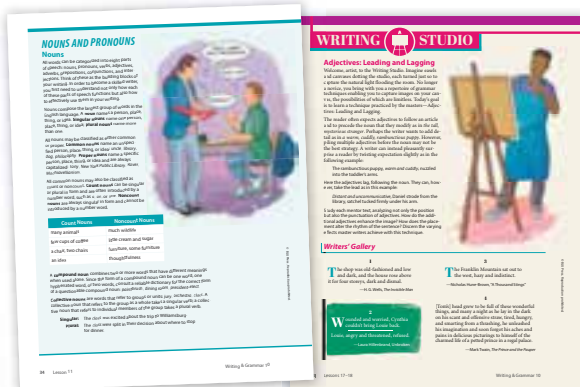



## Instructional Materials

### Worktext (eWorktexts Available)

Student worktexts provide important practice exercises and opportunities for active application to each student's own writing. Our texts encourage students to write regularly and in diverse genres. The main chapters offer a written model and an associated lesson for students to use in studying the model. As students develop their skills, they gain confidence in their skills and preparation for future real-life writing opportunities.

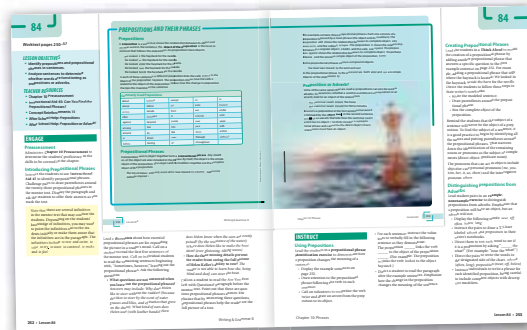

### Teacher Edition

Teacher editions provide instructors with the support they need to teach writing and grammar effectively. Lessons include margin notes for lesson content and planning use, pretests for assessing student knowledge, suggested lesson objectives, differentiated instruction, cross-curricular links, biblical-worldview discussions, and many other tools. These tools help teachers develop their students' knowledge, critical-thinking skills, and biblical worldview.

### Assessments

Assessment packets include summative assessments for grammar concepts. Each assessment aligns with stated objectives available in the teacher edition. Print and digital formats are available. Test bank questions, available with a Trove subscription, are used to create custom print and digital assessments for BJU Press materials (Grades 7–12).



# Course Overview

The chart below summarizes the core content of our writing and grammar series. Note that each subsequent text builds on the material taught in the previous one. Some additional helpful features (such as instruction in study and reference skills) are not listed here. For a more detailed description of each grade's content, visit [bjupress.com/scope/english](http://bjupress.com/scope/english)

## Grammar, Usage, and Mechanics

## Writing Skills

	<ul style="list-style-type: none"> <li>• Reviews all parts of speech.</li> <li>• Reviews and expands all sentence errors, parts of sentences, and sentence types.</li> <li>• Reviews and reinforces conventions and usage.</li> </ul>	<ul style="list-style-type: none"> <li>• Writing projects: personal narrative, newspaper editorial, instructions, research report, historical fiction, compare/contrast essay, limerick, free verse, and cover letter.</li> </ul>
	<ul style="list-style-type: none"> <li>• Reviews the eight parts of speech and five basic sentence patterns.</li> <li>• Corrects major usage problems such as subject/verb disagreement and pronoun reference errors.</li> <li>• Covers basic capitalization, punctuation, and spelling rules.</li> </ul>	<ul style="list-style-type: none"> <li>• Reviews the five-part writing process.</li> <li>• Instructs directly in paragraph organization and development.</li> <li>• Writing projects: narrative, informative, argumentative, and article writing.</li> </ul>
	<ul style="list-style-type: none"> <li>• Reviews all parts of speech, sentence structures, mechanics, and usage from Grade 7.</li> <li>• Presents progressive tense, voice, mood (indicative, imperative, and subjunctive), adjective and adverb clauses, parentheses, brackets, dashes, and ellipses.</li> </ul>	<ul style="list-style-type: none"> <li>• Study and research skill reviews available in the Student Handbook and in the research chapter.</li> <li>• Introduces the six traits of writing, proofreading symbols, writing different types of paragraphs, writing an anecdote, visual representation, writing poetry, writing a business letter, and expanding and combining information.</li> <li>• Writing projects: informative writing, narrative writing, argumentative writing, and multigenre project.</li> </ul>
	<ul style="list-style-type: none"> <li>• Reviews Grade 8 material.</li> <li>• Introduces collective nouns, qualifiers, relative adverbs, verbal phrases with objects, and noun clauses.</li> <li>• Explores study hacks for learning how to learn and self-manage.</li> </ul>	<ul style="list-style-type: none"> <li>• Provides strategies to improve variety and to revise for conciseness and smoothness.</li> <li>• Writing projects: brochure, creative writing, oral presentations, essays, research writing, informative writing, memoir, opinion, book review, personal letter, and business writing.</li> </ul>
	<ul style="list-style-type: none"> <li>• Reviews Grade 9 material, adding the perfect gerund and the passive infinitive.</li> <li>• Reviews capitalization, punctuation, and spelling rules.</li> </ul>	<ul style="list-style-type: none"> <li>• Covers new strategies to achieve sentence emphasis, energy, and logic; presents various modes of writing.</li> <li>• Writing projects: cause-and-effect essay, eyewitness report, and persuasive speech.</li> </ul>
	<ul style="list-style-type: none"> <li>• Reviews Grade 10 material, adding fine points of grammar such as adverb types and perfect or passive verbals.</li> <li>• Reviews capitalization and punctuation.</li> </ul>	<ul style="list-style-type: none"> <li>• Covers paragraph organization strategies and expands on issues in sentence clarity, energy, and logic.</li> <li>• Writing projects: analytical essay, research paper, in-class essay, and narrative poem.</li> </ul>
	<ul style="list-style-type: none"> <li>• Reviews all of the grammar, usage, and mechanics material covered in Grade 11 with minor additions (e.g., absolute phrases).</li> <li>• Challenges students to demonstrate mastery of these concepts in textbook exercises.</li> </ul>	<ul style="list-style-type: none"> <li>• Reviews all writing skills previously covered with some minor additions.</li> <li>• Writing projects: sonnet, research report, video report, extemporaneous essay, issue analysis essay, and college application essay.</li> </ul>

## Pricing

For Teachers

**Teacher Edition** **80.25–84.00**

**Assessments Answer Key** **12.75–13.75**



AfterSchoolHelp

Content available on BJU Press Trove

For Students

**Student Worktext** **32.50–35.75**

eWorktext 32.50–35.75

**Printed Assessments** **6.88–7.39**

eAssessments 6.88–7.39

The Writer's Toolbox (Grades 9–12) 43.00

**Essential items are in bold.**

# MIDDLE & HIGH SCHOOL | Writing & Grammar

## Technology Resources

### BJU Press Trove™ Teacher Resources

Enhance writing and grammar instruction with extra resources that aid in planning and presenting concepts to your students.

- Video segments introduce grammar concepts and rules, teach and review key terms, and go over expectations for writing assignments.
- Editable Microsoft PowerPoint® slides move through grammar concepts, activities, and the writing process, providing teacher demonstrations and mentor text support.
- Trove's assessment feature allows you to create customized quizzes and tests using a bank of questions that correlate with each chapter. You can edit questions and answers and easily create multiple versions of tests to discourage cheating.

See pages 4–9 for more information on BJU Press Trove and availability information.

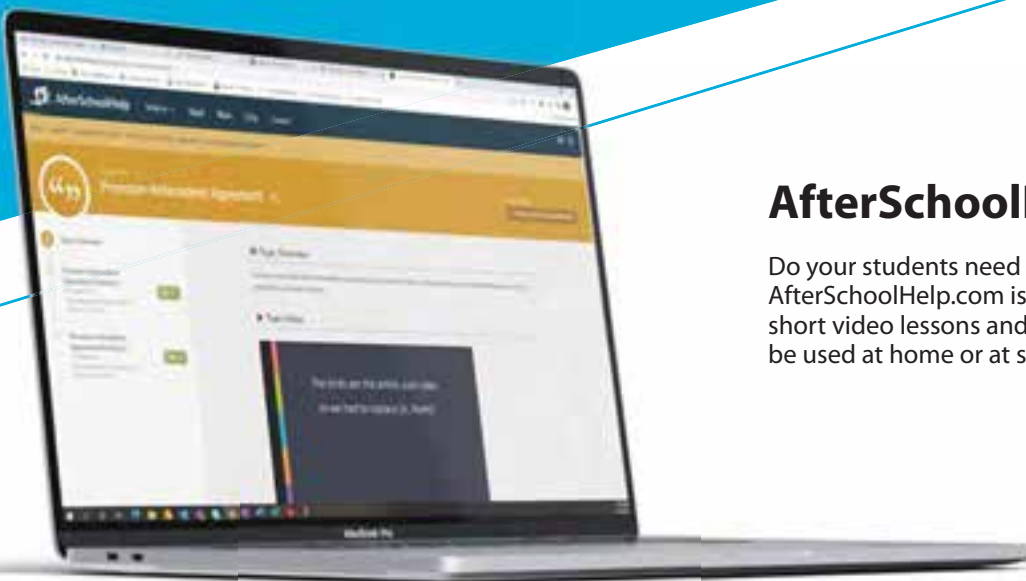

### AfterSchoolHelp

Do your students need extra grammar practice? AfterSchoolHelp.com is a free digital tutor with short video lessons and practice segments that can be used at home or at school.





**BJU Press's spelling product line** equips students to master spelling by recognizing word relationships and structural patterns in grade-appropriate lists. Activities include word study, word sorting, proofreading, dictionary skills, and writing. In the primary grades, word lists contain frequently used words, phonetic words, and challenge words with irregular spellings. In the intermediate grades, lists add syllable patterns and derivational suffixes. Frequent assessments give opportunities for self-assessment and retrieval practice, build student confidence, and encourage mastery for God-honoring written communication.

## Vision

To equip students to master spelling using word-building skills and to apply spelling strategies to God-honoring written communication.

## Goals

- To guide students to develop spelling skills using phonics patterns, word studies, syllable patterns, frequently used words, derivational suffixes and prefixes, and Greek and Latin word parts
- To promote the spelling-meaning connection through word study and word-sorting activities
- To develop spelling consciousness through proofreading and writing activities
- To teach dictionary skills to strengthen students' word knowledge, reference skills, and vocabulary
- To differentiate instruction with activities that meet the needs of individual students

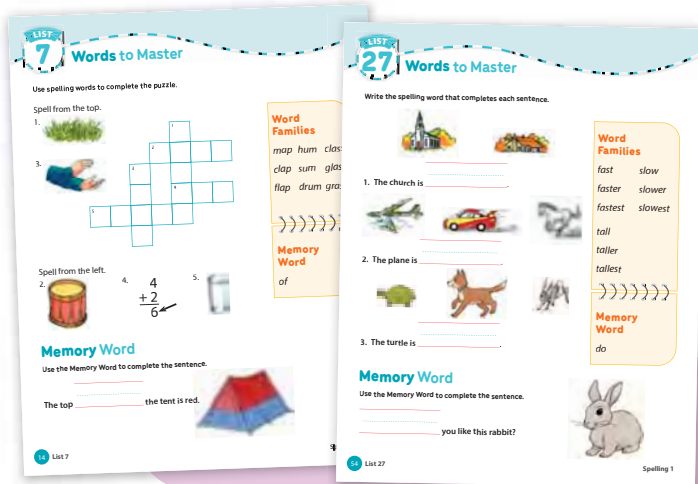



## Instructional Materials

### Worktext (eWorktexts Available)

Worktexts use a word-study approach to help students apply recognizable spelling patterns and rules to unfamiliar words. Each spelling list has engaging activities to apply the skills and strategies students are learning.

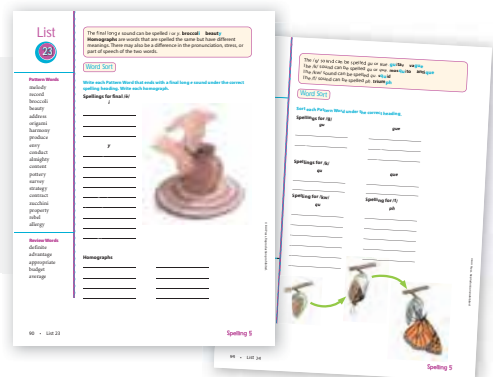

### Teacher Edition

The teacher edition includes lesson planning help, tips for assessing students' understanding, and instructional support for teachers to customize their own lessons. Each edition also has reduced student activity pages with answer overprints for convenient grading.

See Reading 1 and Phonics & English 1 for a complete phonics package.

## Pricing

For Teachers

**Teacher Edition** 32.50–73.00

For Students

**Worktext** 29.25

eWorktext 29.25

Essential items are in bold.

bjupress **trove**<sup>™</sup>  
Content available on BJU Press Trove

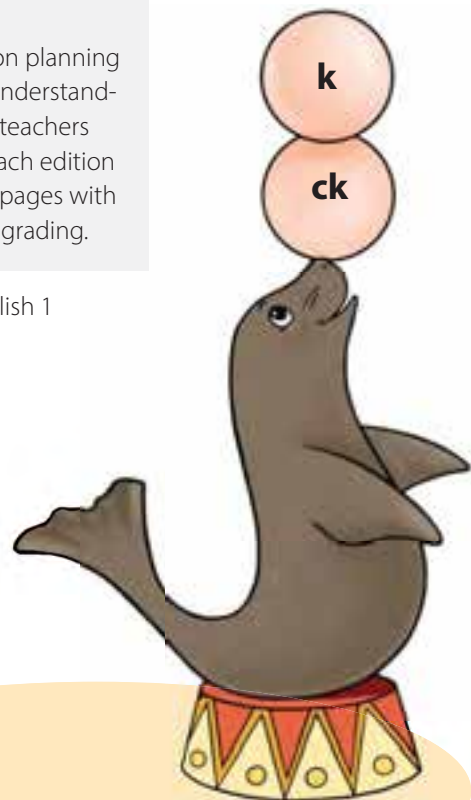

# ELEMENTARY Handwriting



**BJU Press's handwriting program** guides students as they develop individualized handwriting that is natural, legible, and attractive. Beginning in kindergarten and first grade with the forming of letters through patterns, students are taught to write continuous-stroke letters, the foundation of both our PreCursive and cursive systems. Students develop a rhythm and flow that ease the transition to cursive writing in second grade. Learning and reinforcement continue through the sixth grade, where students add calligraphy to their writing skills. Activity pages with engaging themes and cross-curricular content give students opportunities to perfect their handwriting through supported practice, practice from memory, and creative writing.



## Vision

To enable students to develop proper techniques that support the habit of polished handwriting and promote effective written expression.

## Goals

- To develop good posture, correct paper position, and proper tension-free pencil grasp
- To build fine motor skills and encourage mastery of proper letter formation and spacing through frequent practice
- To develop handwriting consciousness, focusing on legibility, automaticity, and consistent pacing
- To promote reading fluency and improved spelling and composition skills
- To develop an appreciation for the art of written expression that serves others and glorifies the Lord

## Pricing

For Teachers

<b>Teacher Edition</b>	<b>49.75</b>
PreCursive Wall Charts	29.25
Cursive Wall Charts	27.00

For Students

<b>Worktext</b>	<b>25.00–31.00</b>
White Writing Paper (ream; Pacon Corp.) (Grades 3–6)	10.75
Calligraphy Pen (Sanford) (Grade 6)	2.26

Essential items are in bold.

## Course Overview

K–2	PreCursive
2–6	Cursive
6	Calligraphy

For more information go to [bjupress.com/category/handwriting-christian-school-curriculum](http://bjupress.com/category/handwriting-christian-school-curriculum)

bjupress **trove**<sup>™</sup>  
Content available on BJU Press Trove





## MIDDLE & HIGH Vocabulary

**BJU Press's middle and high school vocabulary product line** teaches skills for independent vocabulary acquisition and develops a broad working vocabulary to prepare students for effective cultural engagement. Emphasis is placed on explicit instruction that includes inductive vocabulary strategies such as activating prior knowledge and using clues from word parts, etymology, and context. Varied lesson presentations, puzzles, and games keep students interested and motivated, and spiral reviews encourage mastery.

### Vision

To equip students with strategic decoding skills for developing the acquisition of personal vocabulary, improved literacy, and effective oral and written communication.

### Goals

- To give students a working knowledge of common prefixes, roots, and suffixes
- To teach word derivation skills for identifying unfamiliar words in a variety of contexts
- To improve student reading comprehension and fluency through increased vocabulary
- To deepen student understanding of and appreciation for the history of the English language through the study of etymology
- To encourage God-honoring oral and written communication through vocabulary mastery

### Pricing

For Teachers

**Teacher Edition**

**27.00**

For Students

**Student Worktext**

**25.00**



bjupress **trove**<sup>™</sup>  
Content available on BJU Press Trove

**BJU Press's elementary math product line** equips students to master foundational math skills through hands-on manipulatives and sequential teaching that leads students from a concrete to an abstract understanding of mathematics. This process results in deep understanding and long-term retention of mathematical reasoning. Strategic practice and review build computational fluency and prepare students for authentic learning as they connect math concepts to everyday life.

## Vision

To enable students to master foundational math skills by applying consistent reasoning to concrete and abstract models for the purpose of solving problems within the context of a biblical worldview.

## Goals

- To develop number sense through the progression from manipulatives to abstract representations
- To promote computational fluency and automaticity through consistent, strategic practice and spiral review
- To develop a foundation in number systems, fraction theory, algebra, geometry, and statistics
- To build grit and problem-solving skills through meaningful, authentic applications, including word problems and collaborative STEM experiences
- To make sense of mathematical concepts and applications in light of biblical principles

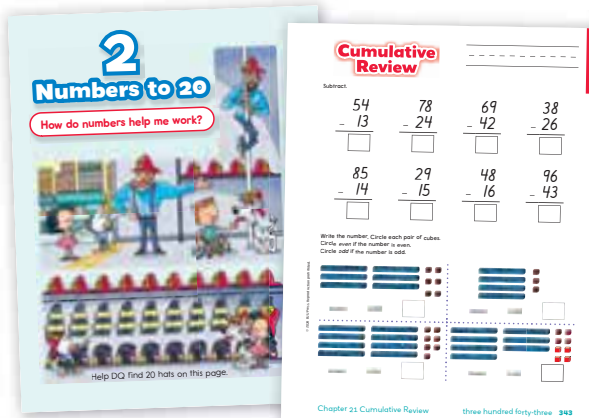

# Instructional Materials

## Worktext (eWorktexts Available)

Our student math worktexts (K5–Grade 5) prepare students to be critical thinkers, using age-appropriate themes that show students how to use math in daily life. Practice opportunities cement understanding, and review sections keep math skills fresh.

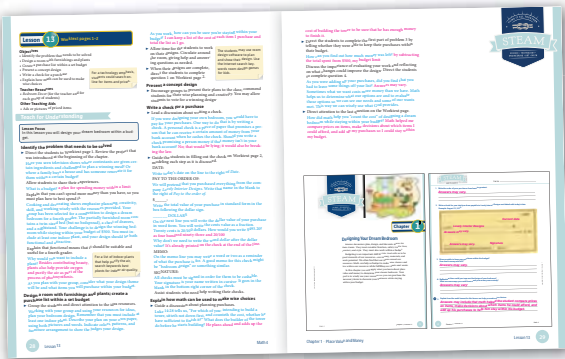
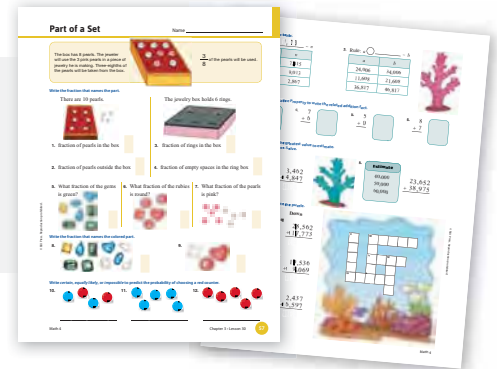

## Teacher Edition

Our teacher editions provide teachers with the support they need to teach math effectively. Each lesson includes suggested teaching strategies, guiding questions, discussion questions, and activities for teachers to choose from to help students learn.

## Reviews—Grades 1–3 (eReviews Available)

Our math review workbooks provide assessments of daily lessons, spiral reviews of previous concepts, fact drills, and cumulative reviews to support and reinforce the concepts taught in the worktext.

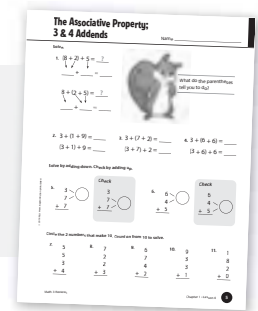

## Activities—Grades 4–5 (eActivities Available)

Our math activity books provide assessments of daily lessons, spiral reviews of previous concepts, and a cumulative review for each chapter.

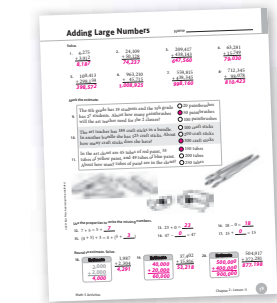

## Teacher's Visuals and Student Manipulatives

Both the teacher's visuals and student manipulatives packets include hands-on learning items, such as number lines, paper coins and bills, rulers, geometric shapes, and fractions. They build and reinforce understanding and introduce new concepts on a concrete, kinesthetic level.



## Assessments

Each assessment packet includes an age-appropriate test for each chapter. Print and digital formats are available. Test bank questions, available with a Trove subscription, are used to create custom print and digital assessments for BJU Press materials (Grades 3–5).



## Course Overview

Below is a summary of the content covered in our elementary math program. For a more detailed scope and sequence, visit [bjupress.com/scope/math](http://bjupress.com/scope/math)

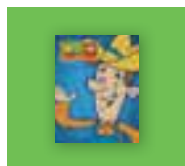

### K5 Math

Uses a manipulative-based, interactive approach to build a strong foundation of number sense; introduces addition, subtraction, measurement, time and calendar, and shapes.

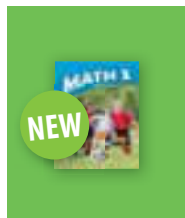

### Math 1

Develops understanding of place value by practicing addition and subtraction; includes the topics of measurement, geometry, time, and money; also introduces skills for writing equations, reading graphs, and solving word problems; applies knowledge with STEM activities.

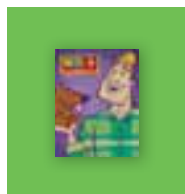

### Math 2

Builds on the understanding of place value by adding and subtracting with two and three digits; also explores fractions, geometry, and measurement and introduces students to foundational multiplication and division skills.

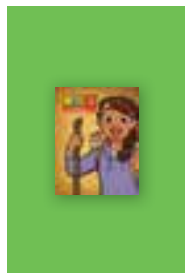

### Math 3

Deepens understanding of place value by applying it to addition, subtraction, multiplication, division, and decimals; strengthens knowledge of division, fractions, geometry, and measurement; also encourages students to recognize the implications of math: that math is a tool, it shows that the world is designed, it helps people, and it has limits; applies knowledge with STEM activities.

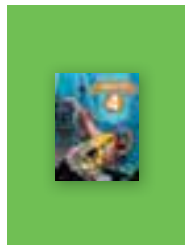

### Math 4

Encourages accurate computation as students apply their knowledge of place value to multiplication and division; also encourages students to use reasoning skills to estimate answers; develops a better understanding of fractions, geometry, measurements, and pre-algebra skills; applies knowledge with STEM activities.

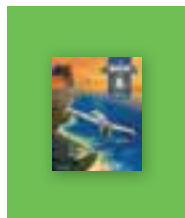

### Math 5

Challenges students to apply their knowledge of operations of whole numbers to decimals and fractions; continues to develop pre-algebra skills and deepens students' understanding of geometry, measurement, and data; applies knowledge with STEM activities.

## Pricing

For Teachers

<b>Teacher Edition</b>	<b>88.50</b>
<b>Assessments Answer Key</b>	<b>12.75</b>
<b>Reviews Answer Key (Grades 1–3)</b>	<b>20.50</b>
<b>Activities Answer Key (Grade 4–5)</b>	<b>20.50</b>
<b>Teacher's Visual Packet</b>	<b>61.75–84.00</b>

For Students

<b>Student Worktext</b>	<b>31.00–35.75</b>
eWorktext (Grades 1–5)	35.75
<b>Reviews (Grades 1–3)</b>	<b>13.50</b>
eReviews	13.50
<b>Activities (Grades 4–5)</b>	<b>13.50</b>
eActivities	13.50
<b>Manipulatives (Grades K5–4)</b>	<b>21.50</b>
<b>Printed Assessments</b>	<b>6.88</b>
eAssessments	6.88

Essential items are in bold.



# Technology Resources

## BJU Press Trove™ Teacher Resources

Help your students gain foundations for math with age-appropriate resources that engage students in the fun of learning.

- Video segments offer counting songs, brief reviews of math terms, and more to get students engaged and interested.
- Editable Microsoft PowerPoint® slides support instruction, work through example problems, and give opportunities for practice and review as a class.
- A searchable, projectable copy of the teacher editions allows you to project answers to daily math activities and review them as a class.
- For Grades 3–5, Trove’s assessment feature allows you to create customized quizzes and tests using a bank of questions that correlate with each chapter. You can edit questions and answers and easily create multiple versions of tests to discourage cheating.

See pages 4–9 for more information on BJU Press Trove and availability information.

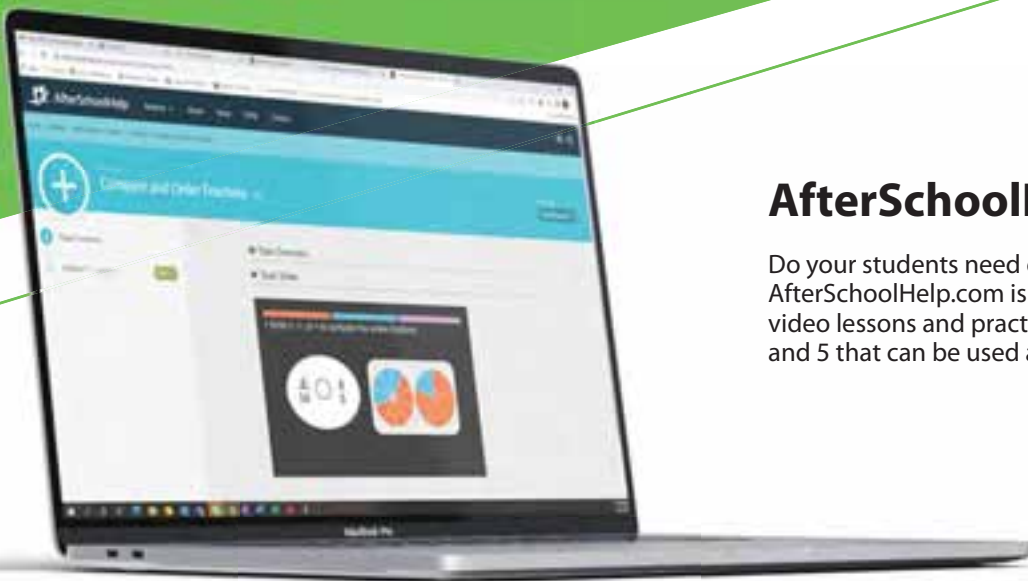

## AfterSchoolHelp

Do your students need extra math practice? AfterSchoolHelp.com is a free digital tutor with short video lessons and practice segments for Grades 4 and 5 that can be used at home or at school.



## Middle School

**BJU Press's middle school math product line** equips students to progress from foundational to more advanced mathematical skills and strategies to solve authentic real-world problems. Skill checks, tiered practice problems, and spiral review develop mathematical skills, and lessons on problem-solving strategies help students see the relevance of mathematical thinking. STEM lessons utilize the engineering design process as a real-world application of mathematical concepts. Instructional videos accessed through QR codes, keyword searches, and some calculator instruction help students use technology to understand math. Cartoons guide students to see math from a biblical worldview.

## Vision

To equip students to progress from foundational to more advanced mathematical skills and strategies with expanded opportunities for abstract reasoning and real-world problem solving within the context of a biblical worldview.

## Goals

- To enable mastery of foundational math skills and develop procedural fluency through logical, consistent reasoning and the use of concrete and abstract models
- To build an understanding of mathematical concepts including number sense, operations, algebra, functions, geometry, probability, and statistics
- To develop analytical thinking by seeing structures and generalizing patterns to aid in authentic and ethical problem-solving
- To develop a biblical view of the role and function of mathematics

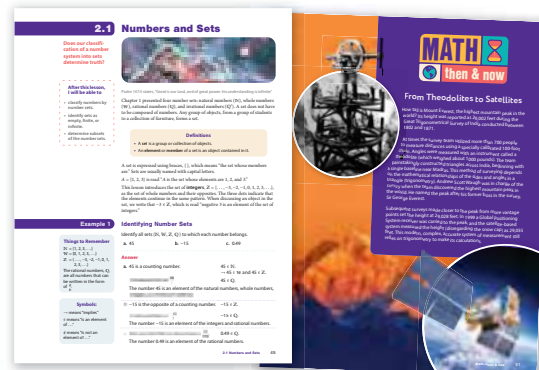

## High School

**BJU Press's high school math product line** equips students to develop advanced mathematical skills and strategies to solve real-world problems in a scaffolded program that extends student understanding through strategic modeling of mathematical procedures, tiered practice problems, and the use and creation of mathematical models in authentic contexts. Targeted keyword searches, graphing calculator instruction, and spreadsheet activities help students use technology to extend their knowledge and skills and apply them to life.

## Vision

To equip students to develop advanced mathematical skills and strategies for analyzing and solving real-world problems through the application of abstract reasoning within the context of a biblical worldview.

## Goals

- To extend an understanding of mathematical concepts including number systems, operations, algebra, functions, geometry, probability, and statistics
- To support student achievement of procedural fluency necessary for college and career readiness through consistent, strategic practice and review
- To develop analytical thinking, reasoning skills, and perseverance in real-world problem solving through the use and creation of models
- To encourage the use of technology to enhance learning, incorporate multiple representations, and remove computational constraints
- To equip students to formulate a biblical view of mathematics





## Instructional Materials

### Student Edition (eStudent Edition Available)

Our math textbooks have clear presentations of concepts with practice exercises that promote student success and prepare students for standardized testing and college-level math courses.

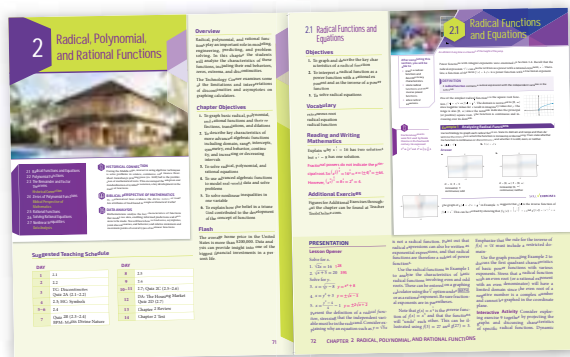
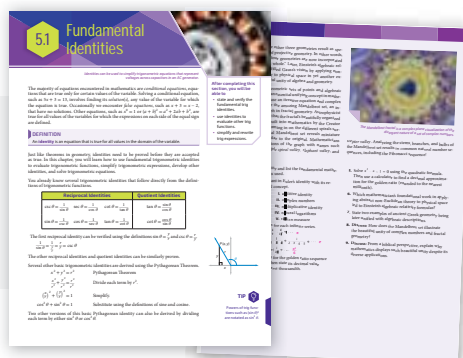

### Teacher Edition

The teacher editions contain presentation suggestions, motivational ideas, and tips to address common student errors. The teacher editions also suggest easy adaptations for scheduling and assignments for minimum, standard, and extended tracks.

### Activities (eActivities Available)

The activity manuals (Grades 7–9) provide resources for extra practice, remediation and enrichment activities, calculator skills, exercises, and unit and chapter reviews. For Math 6, additional activities and reviews are included in the back of the book.

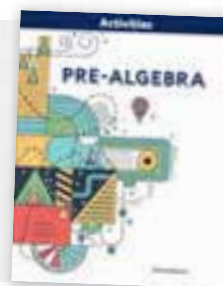

### Assessments

Assessment packets include section quizzes and one age-appropriate test per chapter. Print and digital formats are available. Test bank questions, available with a Trove subscription, are used to create custom print and digital assessments for BJU Press materials.

## Course Overview

Below is a summary of the content covered in our middle and high school math series. For a more detailed scope and sequence, visit [bjupress.com/scope/math](http://bjupress.com/scope/math)

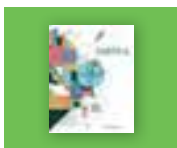

### Math 6

Extends pre-algebra skills by introducing students to ratios, percentages, rates, and integers; also encourages students to think statistically and explore STEM applications.



### Fundamentals of Math (7)

Focuses on problem solving and real-life uses of math through STEM activities with special emphasis on reinforcing computational skills and building a solid math foundation (a foundational course for pre-algebra).

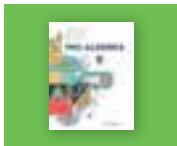

### Pre-Algebra (8)

Evaluates numeric and algebraic expressions involving signed integers and rational numbers; simplifies and solves linear equations, including percentages; practices solving real-world problems with STEM activities; creates multiple representations of linear functions; introduces solving systems of linear equations and concepts in geometry.



### Algebra 1 (9)

Focuses on the integration of algebraic concepts in technology and real-life applications; explores the simplification, solving, graphing, and interpretation of linear, exponential, radical, quadratic, and rational functions manually and with technology; practices solving real-world problems with STEM activities.

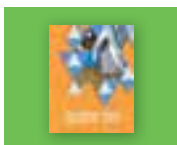

### Geometry (10)

Focuses on the development of higher-level thinking skills through the investigation of parallel and perpendicular lines, congruence and similarity of figures, areas and volumes, symmetry in terms of transformations, and an introduction to trigonometry; incrementally develops paragraph, two-column, flow-chart, and indirect proofs.

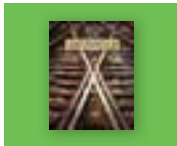

### Algebra 2 (11)

Reviews and extends students' knowledge of linear, quadratic, polynomial, radical, and rational functions and their graphs as well as systems of equations; also explores exponential and logarithmic functions, probability and statistics, trigonometric functions and identities, and the analytic geometry of conic sections.

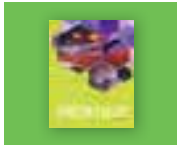

### Precalculus (12)

Reviews algebraic and transcendental functions before focusing on foundations for higher mathematics, including trigonometric functions and their inverses, identities, equations, applications in vectors, polar graphs, complex numbers, matrices, analytic geometry, sequences, series, and descriptive and inferential statistics.

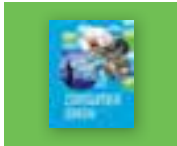

### Consumer Math (12)

Prepares students to make wise financial decisions by discussing topics such as taxes, interest on loans, personal banking, insurance, and more.

## Pricing

For Teachers

<b>Teacher Edition</b>	<b>96.25</b>
<b>Activities Answer Key (Grades 7–9)</b>	<b>45.00</b>
<b>Assessments Answer Key</b>	<b>13.75</b>

For Students

<b>Student Edition</b>	<b>64.75</b>
eStudent Edition	34.00
<b>Activities (Grades 7–9)</b>	<b>22.75</b>
eActivities (Grades 7–9)	22.75
<b>Printed Assessments</b>	<b>7.39</b>
eAssessments	7.39

Essential items are in bold.



AfterSchoolHelp

Content available on BJU Press Trove

# Technology Resources

## BJU Press Trove™ Teacher Resources

Make planning and assessment easy with extra resources that allow you to plan and present concepts to your students in an engaging way.

- Video segments review math concepts and give quick looks into how math applies to other fields.
- Editable Microsoft PowerPoint™ slides support instruction, work through example problems, and give opportunities for practice and review as a class.
- A searchable, projectable copy of the student and teacher editions allow you to project daily activities and work through them as a class.
- Trove's assessment feature allows you to create customized quizzes and tests using a bank of questions that correlate with each chapter. You can edit questions and answers and easily create multiple versions of tests to discourage cheating.

See pages 4–9 for more information on BJU Press Trove and availability information.

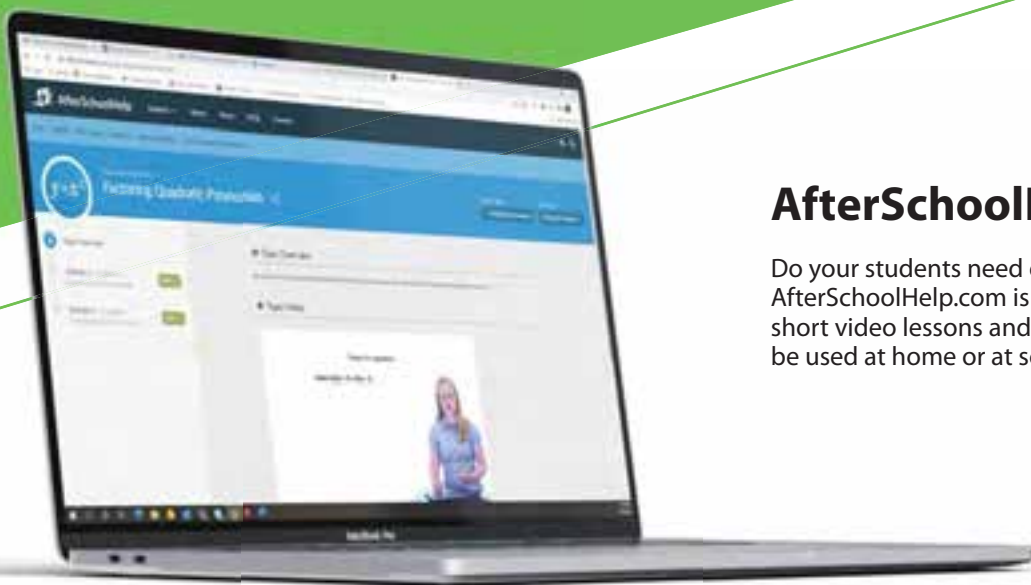

## AfterSchoolHelp

Do your students need extra math practice? AfterSchoolHelp.com is a free digital tutor with short video lessons and practice segments that can be used at home or at school.



# ELEMENTARY Science

**BJU Press's elementary science product line** inspires students to observe and investigate the natural world by developing foundational knowledge and skills with pre-assessments, scaffolded instruction, spiral review, and hands-on activities. Exposure to scientific inquiry gives students opportunities to observe, classify, measure data, analyze data, make inferences, and communicate their findings. Collaborative STEM activities give students opportunities to work together to design, test, and refine engineered solutions to real-world problems.

## Vision

To inspire students to observe and investigate the natural world in order to analyze and evaluate scientific information and models from a biblical worldview.

## Goals

- To develop a foundational understanding of scientific knowledge and skills
- To expose students to scientific methods to solve real-world problems, particularly through collaborative STEM experiences
- To use models to explain and describe observations and make predictions
- To enable students to interpret and apply scientific knowledge through the lens of biblical teaching



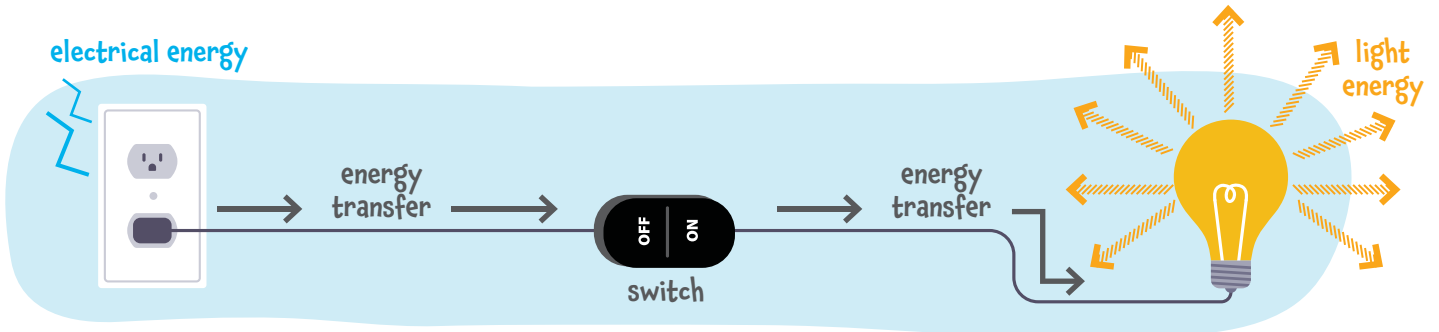

## Instructional Materials

### Student Edition (eStudent Edition Available)

The student edition provides grade-appropriate information through text, diagrams, graphs, charts, and annotated photographs and illustrations. These editions also contain an introduction to each Investigation, Inquiry, Exploration, and STEM activity.

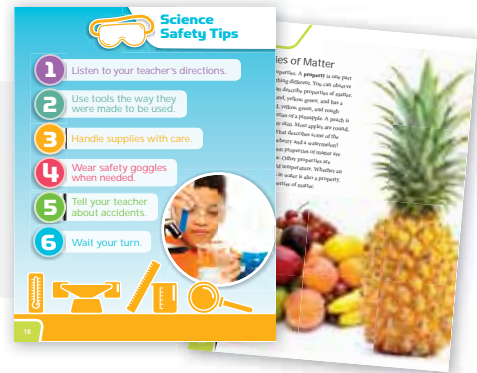
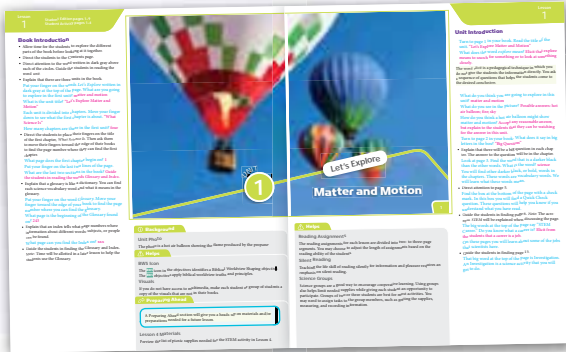

### Teacher Edition

Each teacher edition supports teachers by giving suggestions for implementing effective teaching strategies for each lesson. The teacher editions also provide additional background information, answers to questions, and instructional aids and visuals.

### Activities (eActivities Available)

Our activity manuals are designed to help students learn process skills that can only be gained with hands-on science activities. When used in conjunction with the student edition, the activity manual supports and assesses science objectives.

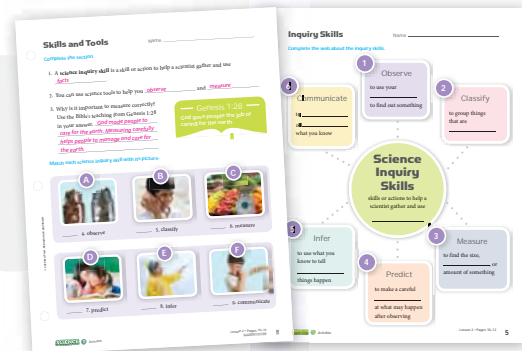

### Assessments

The assessments packet includes regular summative assessments as well as grading rubrics for all STEM, Investigation, Inquiry, and Exploration activities. Print and digital formats are available. For grades 2–5, test bank questions, available with a Trove subscription, are used to create custom print and digital assessments for BJU Press materials.







## Course Overview

Our elementary science textbooks use a spiraled approach to present age-appropriate content. The lower grades lay a foundation for scientific learning with basic, concrete discussions, which the upper grades build on by adding complexity and detail. Through STEM, experimentation, inquiry, and additional project/problem-based learning activities, students learn real-world problem-solving by applying science inquiry skills and the engineering design process. This spiraled approach improves understanding and retention.

Grades 1–3 are single-semester courses. Grades 4–5 contain a full year of lessons.

The chart below is a summary of the content covered in our elementary science program. For a more detailed description of content covered in each grade, visit [bjupress.com/scope/science](http://bjupress.com/scope/science)

	Earth Science	Life Science	Physical Science	Science Skills
	Earth, sun, moon, stars, seasons, weather	Plants, animals, human body, health	Light energy, sound energy, communicating with light and sound	<ul style="list-style-type: none"> <li>• Observe</li> <li>• Measure</li> <li>• Infer</li> <li>• Classify</li> <li>• Predict</li> <li>• Communicate</li> <li>• Hypothesize</li> <li>• Identify and Control Variables</li> <li>• Define Operationally</li> <li>• Experiment</li> <li>• Collect, Record, and Interpret Data</li> <li>• Make and Use Models</li> </ul>
	Earth movement, earth layers, natural resources	Plants, animals, habitats, fossils and dinosaurs, human body systems	Matter, changing matter, forces	
	Rocks, minerals, soil, weather, solar system	Cold- and warm-blooded animals, plants, ecosystems, cells, tissue, organs, human skin	Motion, sound, properties of matter, changing states of matter, electricity and magnetism	
	Water and oceans, landforms and changes, natural hazards, natural resources, rocks, minerals, and conserving resources	Plant structures and functions, plant reproduction, invertebrates, vertebrates, human digestive system, nutrition, skeletal and muscular systems, eyes, ears	Energy and motion, energy and work, waves, light, sound, forces and collisions	
	Layers of earth, minerals and rocks, fossils and dinosaurs, atmosphere, severe weather, forecasting weather	Biomes, ecosystems, plant and animal adaptations, ecosystem changes, human respiratory and circulatory systems	Heat, sound and light, energy, measuring matter, states of matter, physical changes, atoms and molecules, mixtures, solutions	

## Pricing

For Teachers

<b>Teacher Edition</b>	<b>73.00</b>
<b>Activities Answer Key</b>	<b>20.50</b>
<b>Assessments Answer Key</b>	<b>12.75</b>

For Students

<b>Student Edition</b>	<b>51.00</b>
eStudent Edition	26.75
<b>Activities</b>	<b>34.50</b>
eActivities	34.50
<b>Printed Assessments</b>	<b>6.88</b>
eAssessments	6.88

Essential items are in bold.

bjupress **trove**<sup>™</sup>  
Content available on BJU Press Trove





## Science Lab Solutions by Logos Science

Give your students real-world learning experiences by choosing Logos Science!

Science activities give a practical, hands-on application for learning and helps students process and truly understand what they're learning in science lessons. Make conducting lab activities easier by using pre-assembled lab kits for your BJU Press elementary science courses! Your students can share one kit in lab groups of up to four students.

These kits include an addendum and materials for the BJU Press activity manuals so your students can complete activities on all topics. Learn more at [bjupress.com/category/logos-science-lab-kits](http://bjupress.com/category/logos-science-lab-kits)

### Pricing

#### Logos Science Lab Solutions

Grade 1 Logos Science Kit	80.96
Grade 2 Logos Science Kit	107.96
Grade 3 Logos Science Kit	159.58
Grade 4 Logos Science Kit	178.65
Grade 5 Logos Science Kit	159.55

# Technology Resources

## BJU Press Trove™ Teacher Resources

Teach and review science concepts with age-appropriate resources that can make lessons more engaging.

- Short videos introduce or review new science concepts with engaging segments or songs.
- Editable Microsoft PowerPoint™ slides review big questions for the chapter, support instruction, and help introduce and review key terms.
- A searchable, projectable copy of the student and teacher editions make chapter reviews and assignments easier to show.
- For Grades 2–5, Trove’s assessment feature allows you to create customized quizzes and tests using a bank of questions that correlate with each chapter. You can edit questions and answers and easily create multiple versions of tests to discourage cheating.

See pages 4–9 for more information on BJU Press Trove and availability information.



# MIDDLE & HIGH Science



## Middle School

**BJU Press's middle school science product line** equips students to apply solutions to real-world problems by expanding scientific knowledge and skills through lab exercises, case studies, ethics activities, and connections to life. Students use scientific equipment to collect data, which they interpret and use to draw conclusions and make predictions in lab activities. They also design, test, and refine solutions to real-world problems in collaborative STEM projects.

## Vision

To equip students to apply solutions to real-world problems based on scientific research, data, and models within the context of a biblical worldview.

## Goals

- To expand knowledge and laboratory skills in scientific disciplines
- To support students' exploration of real-world problem-solving through scientific methods, including collaborative STEM experiences
- To enable students to interact with physical, virtual, and mathematical models to make predictions
- To enable students to evaluate information and apply scientific knowledge within the context of biblical teaching

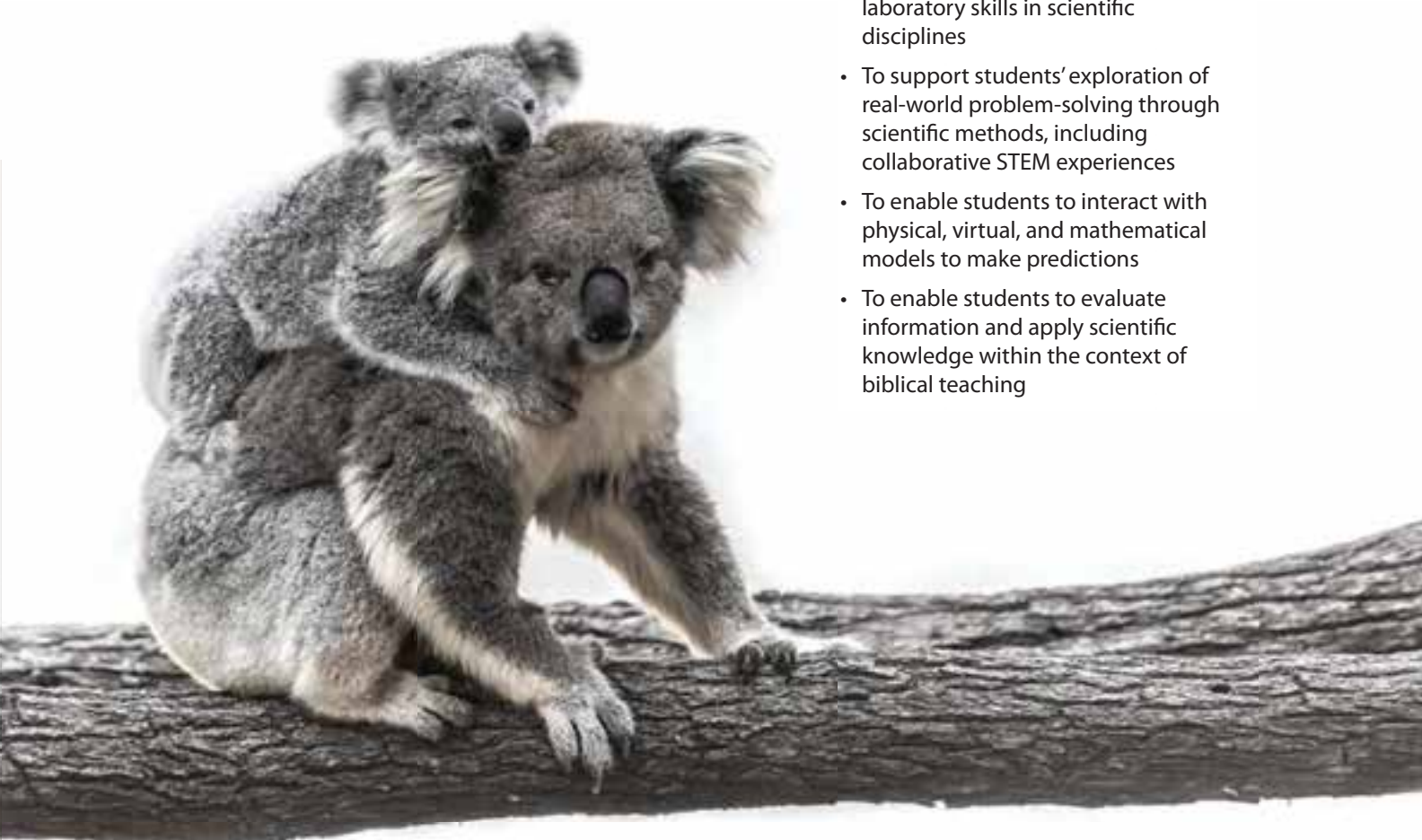

# High School

**BJU Press's high school science product line** motivates students to ethically engage in the work of science through this lab-based program. Students extend knowledge and skills through strategic modeling and practice, case studies, the use and creation of scientific models, and ethics activities. Webquests, spreadsheet activities, and probeware technology build 21st century skills and relate them to the work of science. Students have opportunities to collect and analyze data and create and evaluate their own models through guided discovery labs, inquiry labs, and collaborative STEM experiences.

## Vision

To motivate students to ethically engage in scientific inquiry, data analysis, and model-making to solve real-world problems within the framework of a biblical worldview.



## Goals

- To extend scientific knowledge and laboratory skills
- To engage students in applying scientific knowledge and skills in ethical ways to solve real-world problems, particularly through collaborative STEM experiences
- To enable students to create and use models to describe the natural world by making predictions
- To equip students with the skills to interpret informational text and apply scientific knowledge in accordance with biblical teaching





## Instructional Materials

### Student Edition (eStudent Edition Available)

These beautifully illustrated texts will direct students to study science through the lens of God’s Word, to develop critical-thinking skills, and to work through real-world, science-related problems in STEM activities, case studies, webquests, ethics boxes, and more.

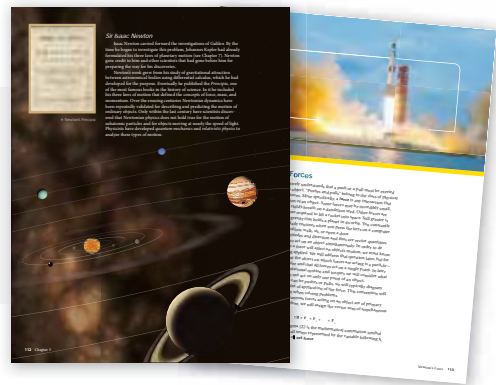

### Teacher Edition

Each teacher edition provides margin notes with answers, discussion topics, and suggested activities, all to support daily lesson planning. Additional resources include rubrics, reproducibles, cross-curricular links, and more.

### Lab Manual (eLab Manual Available)

Lab and activity manuals give students a crucial hands-on experience, allowing them to work directly with the tools and concepts they are studying. Each manual contains a variety of activities, including guided discovery, inquiry, and STEM labs that allow students to think about and discover ideas in science for themselves.



### Assessments

Assessment packets include age-appropriate chapter tests and quizzes focused on key ideas. Print and digital formats are available. Test bank questions, available with a Trove subscription, are used to create custom print and digital assessments for BJU Press materials.

## Course Overview

Below is a summary of the content covered in our middle and high school science program. For a more detailed scope and sequence, visit [bjupress.com/scope/science](http://bjupress.com/scope/science)



### Science 6

Explores the basics of earth science, life science, physical science, and the human body to form a foundation for more specific studies.

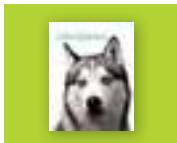

### Life Science (7)

Surveys the structures and functions of living things such as plants, animals, and human beings—concepts that are unfolded as a quest to understand the life that God has created.

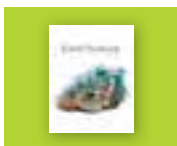

### Earth Science (8)

Moves students from the lithosphere, through the hydrosphere and the atmosphere, to the solar system and the rest of the universe—a journey that develops the students' understanding and appreciation for God's creation.

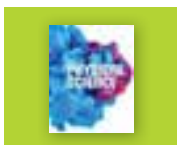

### Physical Science (9)

Discusses the atomic model, elements, compounds, chemical reactions, acids, bases, and salts, as well as classical mechanics, work and energy, wave phenomena, electricity and magnetism, and light and optics to help people and to wisely use God's world.

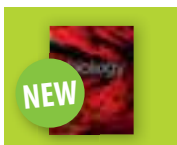

### Biology (10)

Showcases God's power and glory in creation by discussing cellular biology, genetics, taxonomy, microbiology, botany, zoology, and human anatomy (includes an anatomy and physiology supplement).

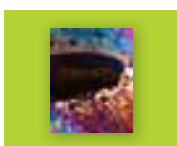

### Chemistry (11)

Gives students the tools to build an understanding of atomic structure, chemical composition, and chemical reactions; helps students discover how this understanding can be used to help people who bear God's image.

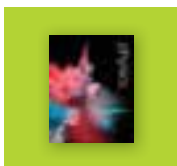

### Physics (12)

Teaches students to extend knowledge and skills through strategic modeling and practice, case studies, evaluation of scientific models, and ethics activities; explores kinematics, dynamics, thermodynamics and matter, electromagnetics, geometric optics and light, and concepts from modern physics to help students ethically engage in the work of physics.

## Pricing

For Teachers

<b>Teacher Edition</b>	<b>73.00–85.75</b>
<b>Lab Manual Teacher Edition</b>	<b>40.00</b>
<b>Activities Answer Key</b>	<b>20.50</b>
<b>Assessments Answer Key</b>	<b>12.75–13.75</b>

For Students

<b>Student Edition</b>	<b>51.00–77.50</b>
eStudent Edition	26.75–40.75
<b>Lab Manual</b>	<b>34.50</b>
eLab Manual	34.50
<b>Activities</b>	<b>34.50</b>
eActivities	34.50
<b>Printed Assessments</b>	<b>6.88–7.39</b>
eAssessments	6.88–7.39

Essential items are in bold.



AfterSchoolHelp



Content available on BJU Press Trove



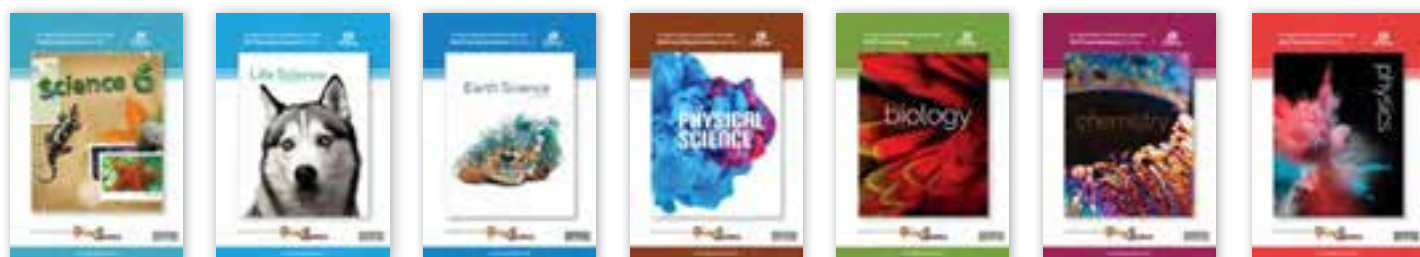

## Science Lab Solutions by Logos Science

Science labs offer a practical and hands-on experience for learning and are critical for students to succeed in a science classroom. But assembling all of the components for an experiment can be difficult or costly. BJU Press offers affordable and accessible science lab solutions with Logos Science kits. These kits include an addendum and materials for the BJU Press lab manuals so that your students can complete labs on all the topics, even in nontraditional environments. One kit can be shared with up to four students. Refill kits replenish items in kits that are not reusable for up to four students. Learn more at [bjupress.com/category/logos-science-lab-kits](http://bjupress.com/category/logos-science-lab-kits)

Give your students a real-world learning experience with Logos Science!

## Pricing

### Logos Science Lab Solutions

Science 6 Lab	155.53
Life Science Lab	223.68
Life Science Lab refill	79.50
Earth Science Lab	234.77
Earth Science Lab refill	52.76
Physical Science Lab	379.84
Biology Lab	check online
Biology Lab refill	check online
Chemistry Lab	321.52
Chemistry Lab refill	68.72
Physics Lab	397.47

# Technology Resources

## BJU Press Trove™ Teacher Resources

Broaden your students' science skills with extra resources that aid in planning and presenting concepts to your students in an engaging way.

- Short videos introduce new skills and concepts. These videos explain concepts visually for a differentiated explanation.
- Editable Microsoft PowerPoint® slides give you support for your instruction, including informative visuals that make demonstrating, displaying, and explaining scientific principles and concepts easier.
- Search and project electronic copies of the student and teacher editions.
- Trove's assessment feature allows you to create customized quizzes and tests using a bank of questions that correlate with each chapter. You can edit questions and answers and easily create multiple versions of tests to discourage cheating.

See pages 4–9 for more information on BJU Press Trove and availability information.

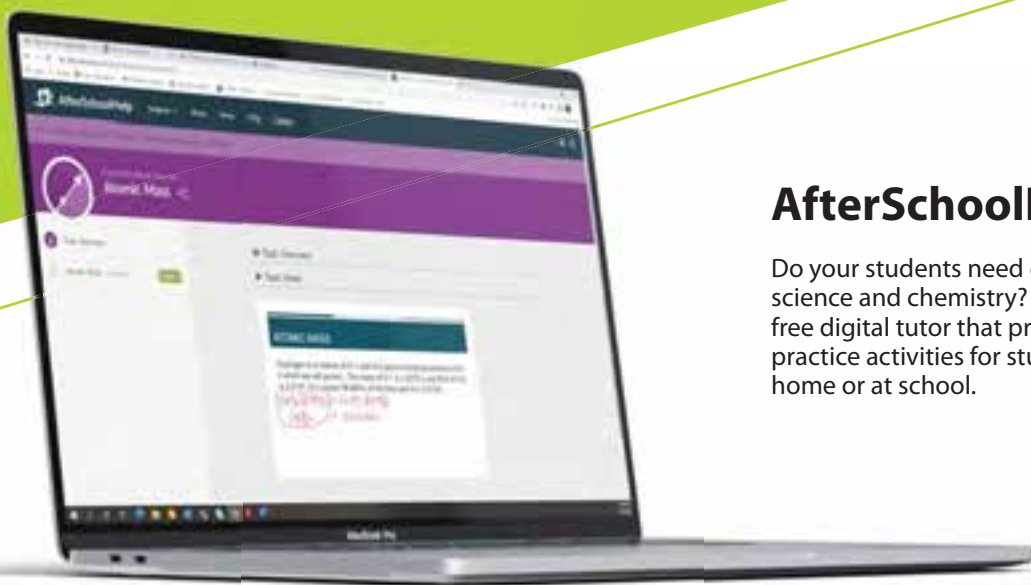

## AfterSchoolHelp

Do your students need extra practice in physical science and chemistry? AfterSchoolHelp.com is a free digital tutor that provides video tutorials and practice activities for students to review concepts at home or at school.



# ELEMENTARY Heritage Studies



**BJU Press's elementary Heritage Studies product line** guides students to analyze and evaluate historical events, world cultures, and primary sources from a biblical worldview. Engaging lessons and activities develop and strengthen 21st century skills through features such as graphic organizers, reinforcement pages, biographies, map skills, and study guides. Cross-curricular links, background information, and interactive visuals help students relate heritage studies to other academic disciplines in order to help them make wise decisions about their world.

## Vision

To equip students to understand, biblically evaluate, engage in, and make decisions about their world.

## Goals

- To develop social studies skills and a foundational understanding of geography, economics, history, government, civics, and culture
- To evaluate sources, cultures, and events from a biblical worldview
- To propose solutions to economic, political, and social problems
- To become lifelong learners who value freedom, equality, and individual responsibility

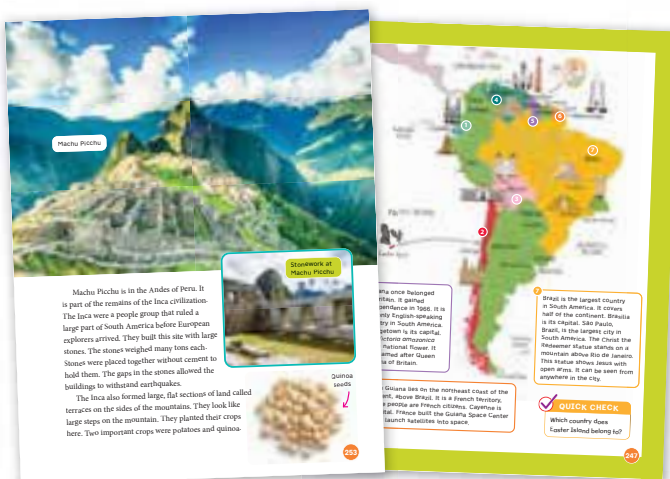

# Instructional Materials

## Student Edition (eStudent Edition Available)

Each student edition combines well-researched content with colorful photos, illustrations, and graphics, and integrates Bible, citizenship, culture, economics, geography, government, and history to give students a strong foundation in social studies.



## Teacher Edition

The teacher edition for each grade contains full-color, reduced-size student pages, plus extras, such as background information, hands-on activities, review games, and songs that make learning memorable. Lessons also provide opportunities for collaboration, creativity and imagination, and technology literacy.

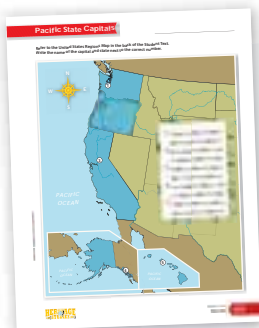

## Activities (eActivities Available)

The activity manual is designed to help students interact with the course material in order to build understanding. Activities include sequencing events, labeling maps, study guides, and much more.

## Assessments

Each assessment packet contains one test per chapter or unit, covering the most important concepts taught in the lessons. Tests include graphic organizers, models, maps, and primary sources. Print and digital formats are available. For grades 2–5, test bank questions, available with a Trove subscription, are used to create custom print and digital assessments for BJU Press materials.



# Course Overview

Our elementary heritage studies textbooks use age-appropriate content to build a solid foundation for future learning. Students will be introduced to social studies skills in geography, economics, history, government, civics, and culture. Grades 1–3 discuss concepts on a basic, concrete level to encourage understanding. Grades 4–5 build on previously established concepts to prepare students for middle school courses. Each grade incorporates skills in literacy, 21st century skills, and map reading.

Grades 1–3 are single-semester courses. Grades 4–5 are full-year courses. For a more detailed description of content covered in each grade, visit [bjupress.com/scope/heritage](http://bjupress.com/scope/heritage)

	Description	Social Studies
	<p><b>Heritage Studies 1: Family and Community</b> Introduces a Christian worldview of the family, community, jobs, land, and the United States. Students learn to relate each aspect of social studies to their own lives and to see how each can prepare them to help out in their communities.</p>	<p>Geography, history, government, economics, culture, addresses and landmarks, sorting and sequencing, visual analysis, literacy</p>
	<p><b>Heritage Studies 2: Community and Government</b> Encourages students to evaluate society and their role in it through the lens of God’s Word. Students will learn how to participate effectively in their world.</p>	<p>Geography, citizenship, government, economics, culture, technology literacy, using source materials, visual analysis, literacy</p>
	<p><b>Heritage Studies 3: World Regions</b> Explores the different world regions to help students to understand, appreciate, and gain an interest in the cultures in each region. Features and region studies will help students to understand the diversity of God’s creation.</p>	<p>Geography, government, economics, history, culture, religion, literacy, primary and secondary sources</p>
	<p><b>Heritage Studies 4: Our United States</b> Explores the history and development of the United States with a regional focus. Students will learn about cultures by exploring the regions of the United States.</p>	<p>Geography, world history, American history, government, economics, culture, cause and effect, visual analysis, primary sources</p>
	<p><b>Heritage Studies 5</b> American history from America’s first peoples to the presidency of Barack Obama; emphasis on map skills and using maps while also developing perspectives on government, economics, and culture.</p>	<p>Civics, culture, geography, government, economics, social studies skills, religion</p>

# Pricing

For Teachers

<b>Teacher Edition</b>	<b>73.00</b>
<b>Activities Answer Key</b>	<b>20.50</b>
<b>Assessments Answer Key</b>	<b>12.75</b>

For Students

<b>Student Edition</b>	<b>47.00</b>
eStudent Edition	24.75
<b>Activities</b>	<b>32.75</b>
eActivities	32.75
<b>Printed Assessments</b>	<b>6.88</b>
eAssessments	6.88

Essential items are in bold.



# Technology Resources

## BJU Press Trove™ Teacher Resources

Help your students understand the foundations of civics and other key heritage studies skills with age-appropriate resources that can make lessons more engaging.

- Short video segments show the stories of history so students can see how the world used to be and see how history connects to today.
- Editable Microsoft PowerPoint™ slides support instruction and include maps and other visuals that help students understand history in context.
- eTextbooks make projecting review questions, maps, and timelines from the books simple!
- For Grades 2–5, Trove’s assessment feature allows you to create customized quizzes and tests using a bank of questions that correlate with each chapter. You can edit questions and answers and easily create multiple versions of tests to discourage cheating.

See pages 4–9 for more information on BJU Press Trove and availability information.



# MIDDLE & HIGH History



## Middle School

**BJU Press's middle school history product line** provides students with opportunities for analyzing and evaluating historical events, as well as introducing primary and secondary sources for point of view, context, and bias. Visual analysis of historical photographs and political cartoons create context while informational boxes, maps, charts, and diagrams help students connect ideas. Thought-provoking questions, differentiated instruction, and active learning strategies develop students as they strengthen their social studies skills and apply a biblical worldview to real-world issues.

## Vision

To develop students' social studies skills and their ability to biblically evaluate culture and events in history in order to become caring and engaged citizens in their world.

## Goals

- To build social studies skills and digital literacy, including reading, researching, analyzing primary sources, mapping, and creating timelines
- To use inquiry, research, and analysis to make connections between related concepts in social studies and in different disciplines
- To guide student evaluation of history and culture by formulating biblical approaches to cultural values including justice, power, freedom, individualism, and equality
- To develop grateful, biblically responsible citizens who evaluate culture, share solutions to real-world problems, and actively participate in their communities



# High School

BJU Press's high school history product line supports students in engaging in their culture by providing opportunities for document-based analysis and historical research. Collaborative projects, cross-curricular links, discussions, and presentations help students apply digital literacy and 21st century skills. Probing questions about ethical citizenship and real-world problems are designed to produce biblically informed citizens and leaders.

## Vision

To equip students to engage in their culture as discerning citizens and to apply a biblical worldview to history, government, geography, and economics.

## Goals

- To support mastery of social studies skills and a thorough understanding of how history is viewed, written, and interpreted
- To extend an understanding of the interrelationship of various disciplines and social studies
- To develop student competency in evaluating historical events, government and economic structures, and world cultures by formulating biblical approaches to justice, power, freedom, individualism, equality, and other core values
- To equip students to create biblical solutions to real-world economic, civic, environmental, political, and social problems to take informed action as biblical citizens



# Instructional Materials

## Student Edition (eStudent Edition Available)

Our student editions make social studies meaningful and relevant through accurate and clear presentation. The textbooks capture students' attention, sustain their interest, and make the information memorable.

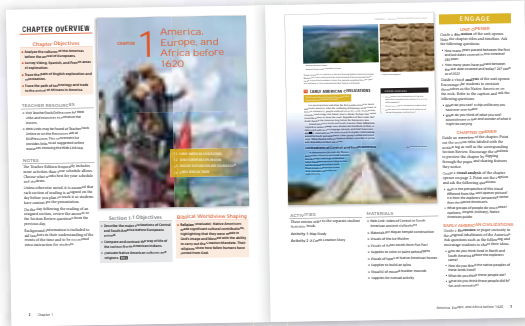
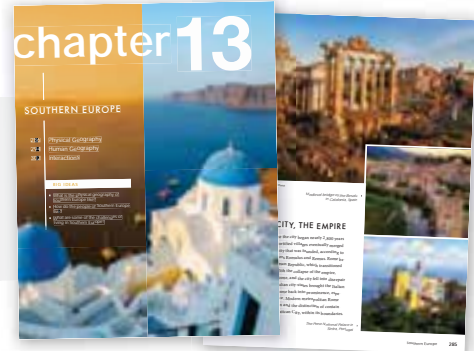

## Teacher Edition

The teacher editions provide teachers the support they need to teach the subject effectively. Each teacher edition also provides tools for promoting student participation and developing critical-thinking skills.

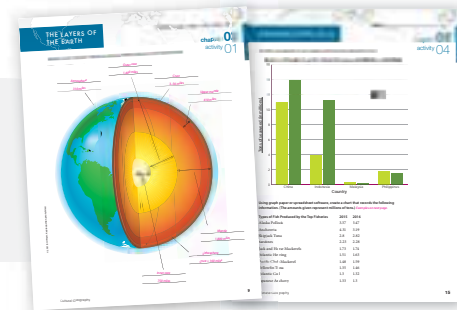

## Activities (eActivities Available)

The activity manuals help students interact with the course material and primary sources to build understanding, review concepts, and help students think critically.



## Assessments

Each assessment packet contains one test per chapter, covering the key ideas from the lessons. Tests include graphic organizers, models, maps, and primary sources. Print and digital formats are available.



## Course Overview

The middle and high school heritage studies textbooks present students with a balanced overview of American and world history as well as geography, American government, and economics and provide them with a better understanding of the world around them.

*American Government* and *Economics* can each be used as either a one- or two-semester course. For a more detailed description of content covered in each course, visit [bjupress.com/scope/heritage](http://bjupress.com/scope/heritage)

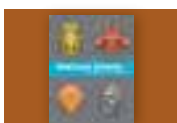

### Heritage Studies (6) Ancient Civilizations

Ancient history (Creation–Middle Ages); emphasis on primary-source evaluations of justice, power, citizenship, and environment; prepares the students for *World Studies* in Grade 7

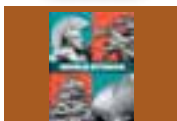

### World Studies (7)

Survey of major events in world history from Europe in the Middle Ages (AD 1300) to the present so students may be equipped to explore and analyze events and develop understanding of political structures, economics, cultures, and religions from a biblical worldview

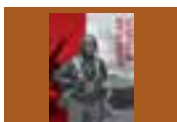

### American Republic (8)

Chronological survey of American history from European discovery to the present with an emphasis on American values and how they shaped American history

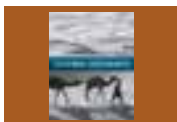

### Cultural Geography (9)

Survey of physical and cultural geography and the interactions between the two, emphasis on biblical worldview with a focus on world religions and how people relate to each other

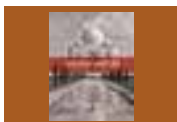

### World History (10)

Chronological survey of world history from Creation to the present, tracing major patterns in world history and analyzing the cultural ideas and practices of civilizations as well as the impact of religion on them

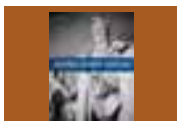

### United States History (11)

Survey of American history from the Colonial Era to the current day; emphasis on primary source analysis as well as evaluations of American culture from a biblical worldview



### American Government (12)

Thorough analysis of all levels and branches of American government along with discussions about political factors that impact the American economy, about American political behavior, and about the scriptural foundation for law and government



### Economics (12)

Study of basic economic topics with an emphasis on applying scriptural principles to all areas of economics

## Pricing

For Teachers

<b>Teacher Edition</b>	<b>73.00–86.75</b>
<b>Activities Answer Key</b>	<b>20.50–43.00</b>
<b>Assessments Answer Key</b>	<b>12.75–13.75</b>

For Students

<b>Student Edition</b>	<b>47.00–69.50</b>
eStudent Edition	24.75–36.50
<b>Activities</b>	<b>32.75–38.00</b>
eActivities	32.75–38.00
<b>Printed Assessments</b>	<b>6.88–7.39</b>
eAssessments	6.88–7.39

Essential items are in bold.





# Technology Resources

## BJU Press Trove™ Teacher Resources

Connect your students to history with extra resources that aid in planning and presenting concepts to your students in an engaging way.

- Short video segments show the stories of history so students can see how the world used to be and how history connects to today.
- Editable Microsoft PowerPoint™ slides include maps and other visuals that help bring history to life and support instruction.
- eTextbooks make projecting review questions, maps, and timelines from the books simple!
- Trove's assessment feature allows you to create customized quizzes and tests using a bank of questions that correlate with each chapter. You can edit questions and answers and easily create multiple versions of tests to discourage cheating.

See pages 4–9 for more information on BJU Press Trove and availability information.





# ELEMENTARY Bible

## Elementary

**BJU Press's elementary Bible product line** is constructed around 147 foundational Bible Truths. These Bible Truths are studied in a systematic way, moving through the big story of the Old and New Testaments, and leading students to appreciate God's grand design for mankind and creation. Elementary Bible strives to instill a greater love for God and His Word by encouraging consistent Bible reading HABITS, singing, and regular Scripture memorization. Elementary Bible helps to bridge the gap between head knowledge and heart knowledge by guiding students as they study, interpret, and apply a biblical worldview.

## Vision

To equip students to begin a relationship with Christ by laying a foundational knowledge of biblical doctrine and the storyline of Scripture and by providing opportunities for students to understand, analyze, and apply Scripture to their lives.

## Goals

- To equip students to read, interpret, and apply the Word of God to their lives
- To teach Bible study skills through modeling and guidance
- To recognize the Bible as the ultimate authority for faith and practice
- To expose students to the Creation, Fall, Redemption storyline of the Bible
- To teach basic Bible doctrines
- To establish students' belief and confidence in the absolute truth of God's Word
- To present the gospel so students can know and testify of Christ as their Savior
- To communicate the basics of a biblical worldview for obedient living in God's world





## Instructional Materials

### Worktext (eWorktexts Available)

Each worktext helps students apply the Bible, practice Bible study skills, and review the lesson content. Colorful activities motivate young students to study and apply Scripture.

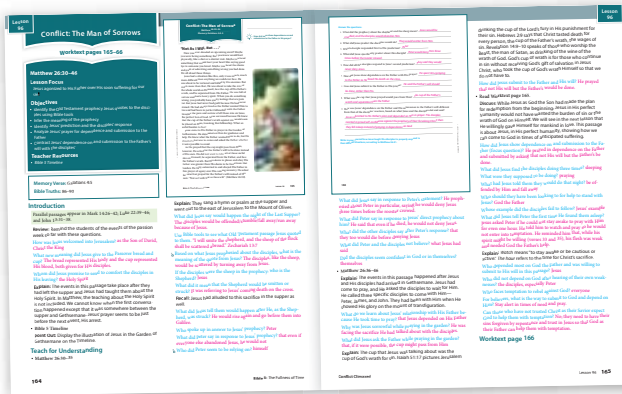
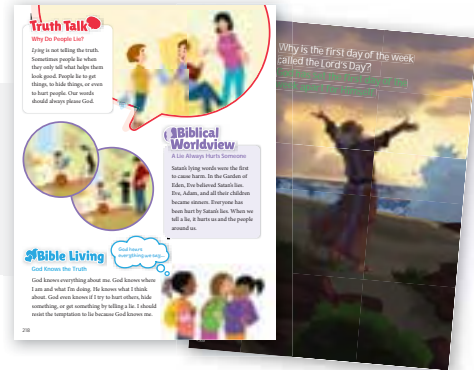

### Teacher Edition

Each teacher edition includes resources for everything from lesson planning to assessing student understanding. Lessons include teaching strategies, discussion questions, answers, and more that support the teacher in customizing lessons according to the individual needs of the students.

### Assessments

Each assessment packet includes one or two age-appropriate tests per unit. Print and digital formats are available.

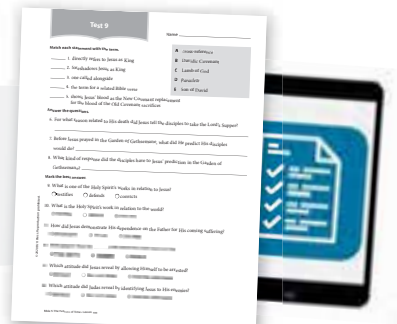

## Course Overview

The chart below provides an overview of the content covered in our elementary Bible classes. The entire program covers most of the stories of the Bible. Each grade may cover the same biblical figures but will cover different parts of the narrative. For a more detailed scope and sequence, visit [bjupress.com/scope/bible](http://bjupress.com/scope/bible)

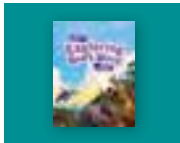

*K5 Bible: Exploring God's Word* introduces your early learners to basic Bible literacy through engaging story cards that help them understand the storyline of Scripture. Discussions and activities reinforce lessons and help students think about the lessons of Scripture.

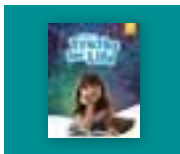

*Bible 1: Truths for Life* explores truths about the Bible with a simple question-and-answer statements. These age-appropriate truths will cover God, His works, the Fall, Christ, salvation, Christian living, and end times. Students will learn the scriptural basis for each truth, its meaning, and its application to their lives.

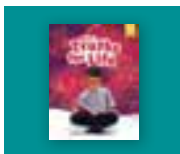

*Bible 2: Truths for Life* continues exploring truths about the Bible through simple question-and-answer statements. Students will review the initial 42 truths from Grade 1 and learn 52 new truths, focusing on biblical covenants, baptism, the Lord's Supper, and end times.

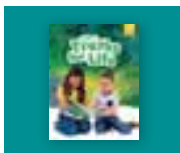

*Bible 3: Truths for Life* introduces 53 new question-and-answer Bible truths and reviews all 147 truths introduced through Grades 1–3. In this course, students will focus on the Ten Commandments and the Lord's Prayer.

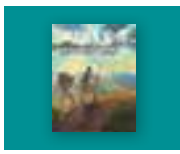

*Bible 4: The Pathway of Promise* shows students that the Bible is the only inspired and authoritative message from God by following the Bible's one story in the Old Testament and highlighting the theme of redemption as it unfolds.

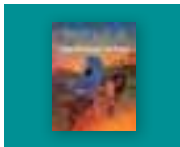

*Bible 5: The Fullness of Time* confronts students with their need for Christ by developing six main themes in God's redemptive plan in the New Testament: glory, kingdom, covenants, divine presence, law and wisdom, and atonement and priesthood.

## Pricing

For Teachers

<b>Teacher Edition</b>	<b>76.00</b>
<b>Assessments Answer Key</b>	<b>12.75</b>

For Students

<b>Worktext</b>	<b>31.00</b>
eWorktext	31.00
<b>Printed Assessments</b>	<b>6.88</b>
eAssessments	6.88

Essential items are in bold.

bjupress **trove**<sup>™</sup>  
Content available on BJU Press Trove



# Technology Resources

## BJU Press Trove™ Teacher Resources

Find unique tools for preparing students to study and apply the Bible with age-appropriate tools and resources.

- Short videos help students think through complicated concepts about the Bible and present animated infographics to explain Bible stories.
- Editable Microsoft PowerPoint® slides include lesson support, memory verses, reviews of Bible truths, and more.

See pages 4–9 for more information on BJU Press Trove and availability information.





# MIDDLE & HIGH Bible

## Middle School

BJU Press's middle school Bible product line leads students to develop a biblical worldview through careful scripture study and memorization, collaborative discussions, case studies, worldview dilemmas, and role playing. As students trace the storyline of the Old Testament and the story of redemption through the life of Christ in the New Testament, middle school Bible provides opportunities for students to practice speaking truth to their neighbors and spreading the gospel to their family and friends.

## Vision

To equip students to grow in their relationship with Christ by building upon a foundation of biblical doctrine, developing a biblical worldview, and systematically tracing Christ through the Old and New Testaments.

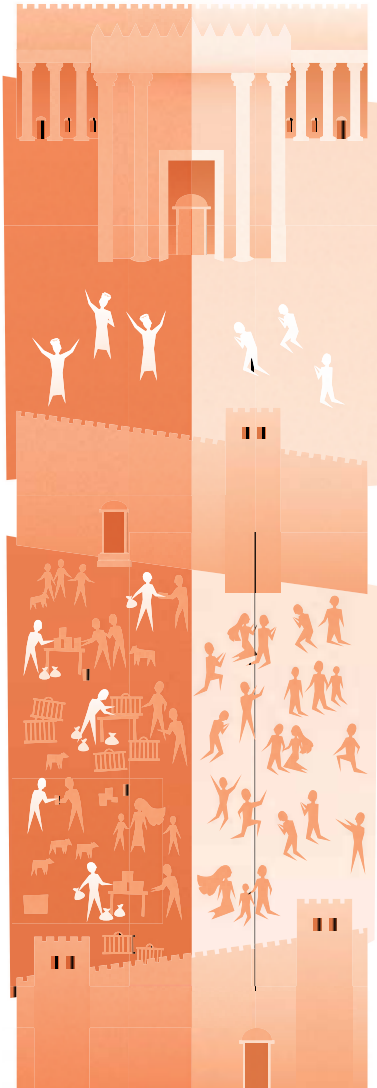

## Goals

- To help students trace the Creation, Fall, Redemption storyline of Scripture
- To enable students to clearly explain their Christian beliefs to their family and friends
- To lead students to value and faithfully apply a biblical worldview to their personal lives
- To develop student ability to observe, interpret, and apply the Word of God to their lives
- To expand Bible study skills through independent and collaborative research and study
- To grow student dependence upon the authority of God's Word
- To help students understand and relate the Old Testament to the New Testament and Jesus Christ



# High School

**BJU Press's high school Bible product line** guides students through a systematic study of the Bible and its significant themes. Students learn to value and use hermeneutical principles based on exegesis through inductive Bible study to explore the Creation, Fall, Redemption story of the Bible, delve into major Bible doctrines, and develop a biblical worldview. High school Bible leads students to formulate and defend a biblical worldview, evaluate other beliefs, and engage in their culture with truth and love.

## Vision

To equip students with biblical literacy, Bible study skills, and biblical doctrine so that they can grow in their relationship with Christ and internalize a biblical worldview in order to develop character, solve real-world problems, and communicate that worldview to others.

## Goals

- To master Bible study skills
- To confirm the Bible as the ultimate authority for faith and practice
- To develop a greater love for God that leads to worship and properly motivated obedience
- To defend biblical doctrine and refute false teaching and philosophies
- To encourage appropriate cultural engagement and evangelism
- To facilitate informed discipleship





## Instructional Materials

### Student Edition (eStudent Edition Available)

Student editions guide students through each level of Bible study, beginning with observation and hermeneutical principles and ending with application. Beautiful illustrations will help students recall lessons, and opportunities for application will enhance students' personal devotions.

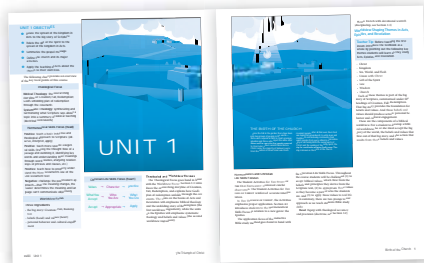

### Teacher Edition

Each teacher edition includes margin notes with teaching notes, strategies, discussion questions, and optional activities. They also offer additional materials and strategies for teaching advanced students and covering different learning styles.

### Activities (eActivities Available)

Each activity manual develops the students' familiarity with Bible study methods and application. They also provide direction for journal activities and verse memorization.

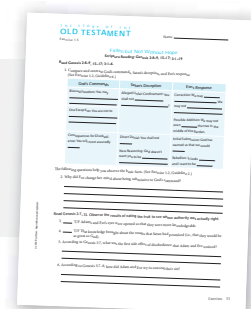

### Assessments

The assessments packets include one age-appropriate test per chapter. Print and digital formats are available. Test bank questions, available with a Trove subscription, are used to create custom print and digital assessments for BJU Press materials.



# Course Overview

Below is a summary of the content covered in our middle and high school Bible program. Visit [bjupress.com/scope/bible](http://bjupress.com/scope/bible) for a more detailed scope and sequence.

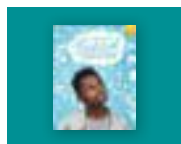

## Basics for a Biblical Worldview (6)

*Basics for a Biblical Worldview* uses case studies, worldview dilemmas, and webquests to challenge students to consider how they think about their world and to recognize the false worldviews that they will encounter. The program uses Bible study skills to help students see the world as it really is.

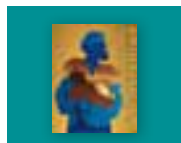

## The Story of the Old Testament (7)

A study of the story of Scripture from Genesis through Malachi; focuses on the Bible study skill of observation.

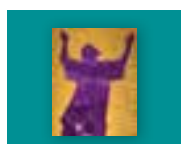

## The Life of Christ (8)

Explores the life of Christ and how He fulfilled God's redemptive plan as promised in the Old Testament; focuses on the Bible study skill of interpretation.



## The Triumph of Christ (9)

Displays the triumph of Christ and His gospel in the founding of the church in Acts and in the consummation of the Kingdom in Revelation; showcases the teaching of the apostles for our beliefs in the Epistles; focuses on the Bible study skill of application.

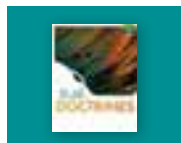

## Bible Doctrines (10)

Teaches the scriptural bases for the major doctrines—God's Word, God (the Father, Son, and Holy Spirit), Creation (man, sin, and angels), salvation, Israel and the church, and last things—so students can formulate their beliefs and apply those beliefs to their lives to develop values.

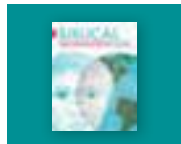

## Biblical Worldview: Creation, Fall, Redemption (11)

This course presents a positive presentation of a biblical worldview with a Bible-first perspective. It then applies that biblical worldview to all of life and culture, emphasizing that Christians must be salt and light.

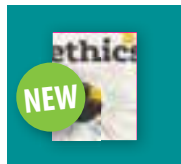

## Ethics (12)

Encourages students to grow in character and biblical thinking so they can make wise ethical choices and defend the Christian faith from a biblical worldview. Students will compare different systems of ethics, learn to defend biblical Christianity, and approach ethics in a way that empowers growth and discernment.

## Pricing

For Teachers

<b>Teacher Edition</b>	<b>47.00</b>
<b>Activities Answer Key</b>	<b>20.50</b>
<b>Assessments Answer Key</b>	<b>13.75</b>

For Students

<b>Student Edition</b>	<b>29.25</b>
eStudent Edition	15.25
<b>Activities</b>	<b>24.25</b>
eActivities	24.25
<b>Printed Assessments</b>	<b>7.39</b>
eAssessments	7.39

Essential items are in bold.

bjupress **trove**<sup>™</sup>  
Content available on BJU Press Trove



# MIDDLE & HIGH SCHOOL | Bible Technology Resources

## BJU Press Trove™ Teacher Resources

Find unique tools for preparing students to study and apply the Bible with resources that can make lessons more engaging.

- Short videos help students think through complicated concepts about the Bible and present animated infographics to explain Bible accounts.
- Editable Microsoft PowerPoint™ slides give you lesson support, including discussion questions, visuals, and more to aid in quick lesson preparation and students' visual engagement.
- Search and project electronic copies of the student and teacher editions to aid in discussion and make going over student reviews and assignments easier.
- For Grades 6–10 and 12, Trove's assessment feature allows you to create customized quizzes and tests using a bank of questions that correlate with each chapter. You can edit questions and answers and easily create multiple versions of tests to discourage cheating.

See pages 4–9 for more information on BJU Press Trove and availability information.



# HIGH SCHOOL Spanish

*¡hola!*

**BJU Press's secondary Spanish product line** equips students to engage in practical communicative exchanges by instructing through the active use of language in a cultural context. Students participate in regular practice through activities and audio files and build skills through listening, reading, writing, and speaking. These products support the development of proficiency as they relate to students' everyday life, personal interests, and studies and shape a biblical view of cultural engagement.

## Vision

To equip students to engage in practical and meaningful communicative exchanges in Spanish with proficiency and cultural awareness.

## Goals

- To develop vocabulary and linguistic structures needed for language acquisition
- To develop level-appropriate interpretive, interpersonal, and presentational communication through language functions within a meaningful context
- To expose students to authentic texts in Spanish
- To develop proficiency through exposure, comprehension, and language production
- To build awareness and appreciation of Hispanic culture, including music, art, food, clothing, and literature
- To prepare students to apply a biblical worldview in cultural engagement



## Spanish Course Overview

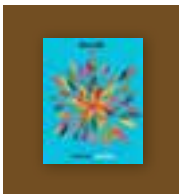

### Spanish 1

Rather than focusing purely on grammar studies, this program develops students' skills in communication and comprehension in the language. Students will experience the language in a communicative context, making language acquisition more natural. The student edition and teacher edition align with the ACTFL (American Council on the Teaching of Foreign Languages) World-Readiness Standards for Language Learning, and they reflect the best practices from the field of second-language acquisition.

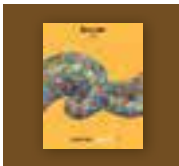

### Spanish 2

This research-based and best-practice-focused program allows students to acquire Spanish at the intermediate level of proficiency on the ACTFL scale. Important language functions are presented within each chapter's cultural theme and developed through activities that are designed to develop the interpretive, interpersonal, and presentational modes of communication.

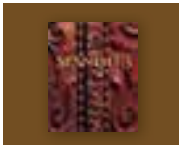

### Spanish 3

*Spanish 3* further develops students' mastery of vocabulary, oral communication skills, and grammatical structure with a special focus on verb forms. The text features true stories and letters from missionaries in Spanish-speaking countries. The student text teaches both language and culture.

## Pricing

For Teachers

<b>Teacher Edition</b>	<b>76.00</b>
<b>Activities Answer Key</b>	<b>35.75</b>
<b>Assessments Answer Key</b>	<b>13.75</b>

For Students

<b>Student Edition</b>	<b>61.75</b>
eStudent Edition	32.50
<b>Activities</b>	<b>32.50</b>
eActivities	32.50
<b>Printed Assessments</b>	<b>7.39</b>
eAssessments	7.39

Essential items are in bold.



AfterSchoolHelp

Content available on BJU Press Trove

# MIDDLE & HIGH SCHOOL | Spanish

## Technology Resources

### BJU Press Trove™ Teacher Resources

Give students an authentic Spanish-learning experience with tools and resources for planning and presentation.

- During lessons, you can access audio files to give students examples of conversations between native Spanish speakers.
- Editable Microsoft PowerPoint® slides help you with introducing new vocabulary, displaying conjugation charts, presenting practice conversations, and much more.
- Short videos help students understand cultures in Spanish-speaking countries.
- eTextbook copies of the student and teacher editions make displaying conjugation charts, visuals, and assignments quick and easy!

See pages 4–9 for more information on BJU Press Trove and availability information.

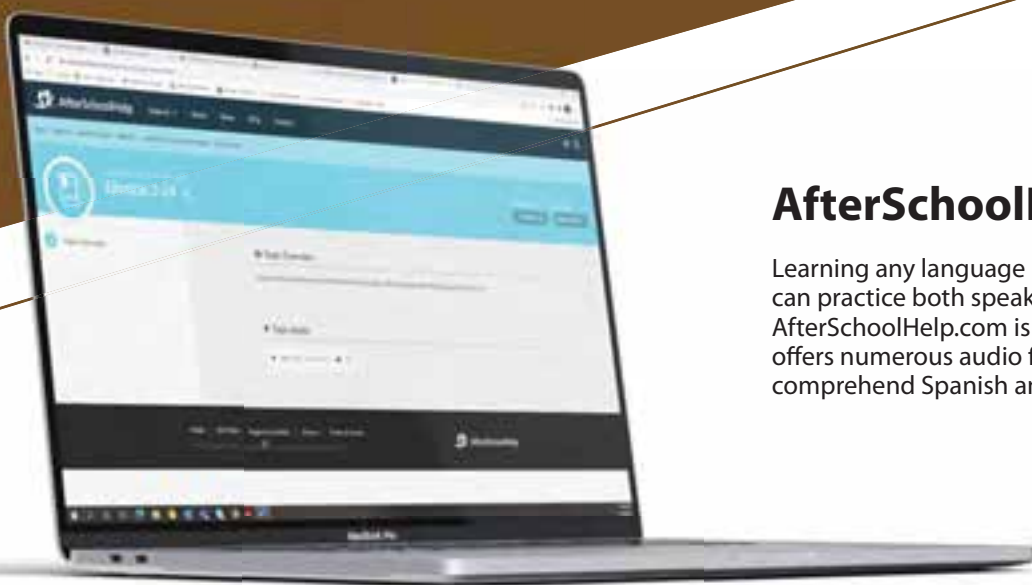

### AfterSchoolHelp

Learning any language is easier when students can practice both speaking and listening at home. AfterSchoolHelp.com is a free digital tutor that offers numerous audio files to help students better comprehend Spanish and speak it more effectively.

# Elementary Spanish

## Strategic Head Start

Children often learn languages faster and more easily than adults, so why not start them early? In our global economy, it is extremely beneficial to know a second language—especially Spanish. BJU Press offers an exciting elementary Spanish program to jump-start your students’ language education.

## Multifaceted Approach

Through reading, writing, speaking, and listening activities, students become familiar with real-life language and proper grammar. The program also covers culture and history so that students become acquainted with context early on.



**Kit A now includes the new DVDs with videos introducing vocabulary and culture. Videos are also available on BJU Press Trove.**

## Pasaporte al español Kit A (Grades 1–3)

Kit A provides progressive steps that build a foundation for students as they listen and learn to speak, read, and write the language.

### Lower Elementary

For Teachers

**Pasaporte al español Kit A (Grades 1–3) 503.25**

For Students

Worktext Step 1 (Grades 1–3)	31.00
Worktext Step 2 (Grades 1–3)	31.00
Worktext Step 3 (Grades 1–3)	31.00

Optional CD Set

CD Set (4 CDs included in Grades 1–3 kit) 111.00

*\*Pasaporte al español Kit A includes teacher edition (Steps 1–3), student worktexts (Steps 1–3), charts, CD set (4 CDs), read-aloud books, and a hedgehog hand puppet named Choco.*

## Pasaporte al español Kit B (Grades 4–6)

Kit B builds on the Kit A foundation (or its equivalent). Students will practice listening, speaking, reading, and writing the language as they learn more about Spanish vocabulary, grammar, and culture.

### Upper Elementary

For Teachers

**Pasaporte al español Kit B (Grades 4–6) 503.25**

For Students

Worktext Step 4 (Grades 4–6)	31.00
Worktext Step 5 (Grades 4–6)	31.00
Worktext Step 6 (Grades 4–6)	31.00

Optional CD Set

CD Set (4 CDs included in Grades 4–6 kit) 111.00

*\*Pasaporte al español Kit B includes the teacher edition (Steps 4–6), student worktexts (Steps 4–6), charts, CD set (4 CDs), read-aloud books, and an iguana hand puppet named Nacho.*



**Kit B now includes the new DVDs with videos introducing vocabulary and culture. Videos are also available on BJU Press Trove.**

**Note:** The teacher should have a basic knowledge of Spanish grammar and pronunciation to teach effectively.

# Additional Resources

## Math

### Backyard Math with Zac

As a supplemental review or home enrichment, Zac and Mrs. Walker will enhance your first-grade math learning experience.

204610 *Backyard Math with Zac* DVD Set (2 DVDs; 180 min.; Grade 1) 19.95

## Reading

### Up the Ladder

Ten paperback readers for beginners with each book containing three two-page stories and a word-family drill at the end.

109223 *Up the Ladder* (10 supplemental readers) 12.60

### The Starting Line

Twelve storybooks for beginning readers.

109363 *The Starting Line* (12 storybooks; Grades K5–1) 18.00

### Take-Along Stories

Stories for first- and second-grade-level readers with vocabulary adapted especially for new readers.

087221 *Take-Along Stories 1* (16 storybooks; Grades 1–2) 18.00

182196 *Take-Along Stories 2* (10 storybooks; Grades 1–2) 18.00

## BJ BookLinks

	Novel	Grade	Lexile	Price
088377	<i>Once in Blueberry Dell</i> , Watkins (Grades K4–1)	K4–1	550	6.29
239038	<i>Buttercup Hill</i> , Berry (Grades 1–2)	1	340	8.09
229203	<i>Looking for Home</i> , Berry (Grades 1–2)	1	450	8.09
057596	<i>Pulling Together</i> , Watkins (Grades 1–2)	1–2	450	8.09
043182	<i>The Treasure of Pelican Cove</i> , Howard (Grades 2–4)	2–4	410	8.09
021782	<i>These Are My People</i> , Howard (Grades 2–4)	2–4	670	8.09
107797	<i>The Case of the Dognapped Cat</i> , Howard (Grades 2–4)	2–4	540	8.09

## Art

### With Art in Mind

No experience necessary! Sixty simple, step-by-step art lessons.

121749 *With Art in Mind*, Groebner (BJU Press; Grades 3–8) 28.75

## Spanish

Stories that teach Spanish words and phrases. Interactive CD also available.

076398	<i>El Pato Paco</i> , Turner and Kitching (Grades 1–5)	6.29
180281	<i>Rosa la Osa</i> , Turner and Kitching (Grades 1–5)	6.29
115022	<i>¡Buenos Días, Carlitos!</i> , Holmes (Grades 1–5)	6.29
180455	<i>¡Buenas Tardes, Carlitos!</i> , Holmes (Grades 1–5)	6.29
092684	<i>Santa Biblia</i> (Reina-Valera, 1960; Broadman and Holman; Grades 9–12)	11.00

## Vacation Stations

Students can build confidence with two pages a day of reviews in math, language, and reading. Vacation Stations blend grade-appropriate practice with colorful characters and exciting themes.

233445	<i>Beyond the Back Door</i>	15.00
506345	<i>Wheels Westward</i>	15.00
503581	<i>Ocean Expedition</i>	15.00
506352	<i>Jungle Journey</i>	15.00
508754	<i>Polar Explorer</i>	15.00
508762	<i>Outback Odyssey</i>	15.00
506360	<i>Egyptian Excursion</i>	15.00

## Science

### Dissection Kit

Compatible with BJU Press life science and biology courses. Kit includes an earthworm, a crayfish, a perch, and a grass frog (4th edition kit also includes a rat) preserved in odorless and non-toxic form and vacuum-packed. Dissecting tools with vinyl case are included, as well as a magnifying glass, Econopan, student activity book, tissue packet, self-sealing storage bag, dissection pins, and towelettes.

034264	<i>Dissection Kit</i>	78.75
276576	<i>Biology Dissection Kit</i> (Grades 7, 10)	77.25

### Biology Dissection Labs DVD

Demonstrates frog, crayfish, perch, and earthworm dissections; identifies organs and systems and discusses their functions.

205773	<i>Biology Dissection Labs DVD</i> (72 min.; ShowForth; Grades 7, 10)	49.95
--------	---	-------

### The Stars Speak (2nd Edition) by Stewart Custer

Points to the glory of God as the central message of the stars.

188391	<i>The Stars Speak: Astronomy in the Bible</i> , Custer (Grades 7–12)	19.50
--------	---	-------

## Heritage Studies

### Church History

Learn the stories behind general church history as well as American church history.

046441	<i>Faith of Our Fathers: Scenes from Church History</i> , Sidwell (Grades 7–12)	12.00
056861	<i>Faith of Our Fathers: Scenes from American Church History</i> , Sidwell (Grades 7–12)	13.00

### American History in Verse

Recapture the joys and struggles of our nation's birth and growth in this inspiring collection of poems.

001768	<i>American History in Verse</i> , Stevenson (Grades 7–12)	11.00
--------	--	-------

## Language Skills

### Someday You'll Write by Elizabeth Yates

A world-famous author shares helpful suggestions and writing basics from her rich store of experience and success. Includes such topics as getting ideas, persistence, and more.

087247	<i>Someday You'll Write</i> , Yates (Grades 3–12)	8.09
--------	---	------

# Testing & Evaluation

## Online Testing: Testing Made Easy

BJU Press offers online testing with *DataManager*.

### Benefits of online testing



Fast Results (as soon as 2 days)



No physical materials—  
no shipping or storage!

### Introducing the BJU Press Testing Advantage from Riverside Insights

Our new, low-cost packages allow expanded access to the Riverside suite. Bundling options per student package include multiple uses of:

- *Iowa Assessments* surveys for admissions testing
- *Iowa Flex* testing for benchmarking and immediate adjustments to instruction
- Use of full conventional spring/fall testing (*Iowa Assessments* with or without *CogAt*®)

For more information on products, set-up, technical readiness checks\*, prices, and more, please see [bjupress.com/testing/online](http://bjupress.com/testing/online)



\*Online testing is subject to the school's hardware and bandwidth as well as the availability of the *Iowa Assessments* Form E in your area.





## Paper-and-Pencil Testing

Results for *Iowa Assessments*™ are typically available in 10–20 business days.

### Purchase Tests

Save money over time

- Order materials once to keep
- Order answer booklets/documents and scoring annually

### Service Package

One easy order provides

- One-time use of testing/directions booklets
- Answer booklets/documents
- Test scoring

See [bjupress.com/go/order-tests](http://bjupress.com/go/order-tests) for more information on these options, FAQs, and order placement.

### *Iowa Assessments*™

BJU Press offers a quality testing experience with *Iowa Assessments*™, Form E (©2012, normed in 2017).

Benefits include:

- **Lexile® Framework for Reading** and **Quantile® Framework for Mathematics** for Grades K5–12.
- Great opportunity to measure incoming students.
- Demonstration of a school's academic success
- Testing students in areas like math, reading, language, science, and social studies.

### Testing with *CogAT*®

In addition to annual achievement testing, assessing student potential in certain grades is invaluable. The *Cognitive Abilities Test*™ (*CogAT*®) is a great tool for this.

Benefits include:

- Ability profile to help sharpen student skills.
- Identification of gifted students.
- Information on how individual students learn.
- Testing students in verbal, quantitative, and nonverbal areas.

## Additional Tools and Resources

### *Iowa Algebra Aptitude Test*™

Find out whether your students are ready for algebra by using a simple, quick, and self-scoring test. Recommended for Grades 7–8.

### Our customers say . . .

"We love this testing! It's thorough and shows exactly where the gaps are and where we are excelling. This isn't our first year using it and it definitely won't be our last either."

"I highly recommend Iowa testing through BJU Press. I was nervous about online testing, but the staff walks you through the whole process. They are very responsive."



## Additional Technology Resources

Because we are committed to equipping teachers with all the resources they need for success, our technology resources work to enhance the value of BJU Press materials. Each technology resource is designed with teachers in mind to make high-quality, useful content easily accessible. We offer homework help, professional development, educational resources, test curation, and much more across our easy-to-use, affordable technology resources platforms.





# AfterSchoolHelp

AfterSchoolHelp.com

## Extra Help Whenever They Need It

Your students can access free tutorials and extra practice for their BJU Press math, English, and Spanish courses when they use **AfterSchoolHelp.com**. All material is searchable by chapter and lesson numbers from BJU Press textbooks.

This student resource offers speed drills for elementary grades, supports English 4–12, math, Spanish, physical science, and chemistry.

## Available Courses

### Math

- Math 4–12
- Consumer Math
- Speed drills

### Language Arts

- English 4–6
- Writing & Grammar 7–12

### Spanish

- Listening selections

### Science

- Physical Science
- Chemistry

AfterSchoolHelp.com provides free access to extra resources such as:



Video Tutorials



Practice Activities

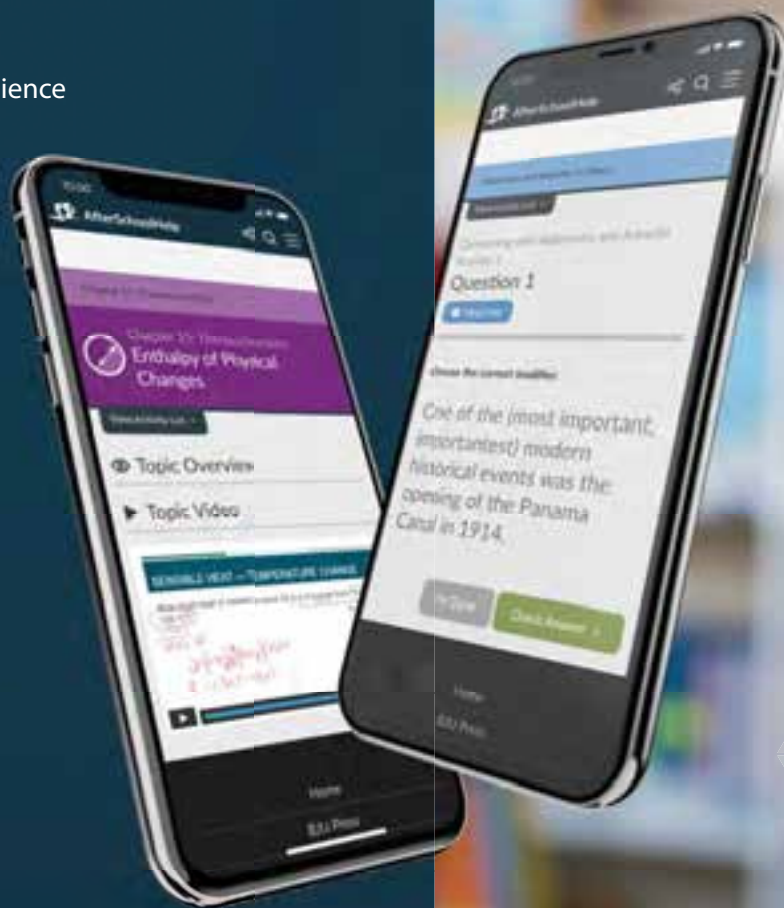



## Integrate Our Textbooks by Using Curriculum Trak

BJU Press is offering two new ways to make it easier to integrate our textbooks into your curriculum!

1

Course maps of BJU Press materials, objectives, resources, and strategies

2

Create your own custom curriculum maps with Curriculum Trak software

We have partnered with Curriculum Trak to create detailed maps of our materials. These maps give all objectives, topics, resources, biblical integration concepts, and instructional strategies for each textbook. Find BJU Press curriculum maps at [bjupress.com/go/curriculum-maps](http://bjupress.com/go/curriculum-maps)

Curriculum Trak offers software designed for schools to easily build your own custom curriculum maps. Learn more about CT software at [curriculumtrak.com](http://curriculumtrak.com)

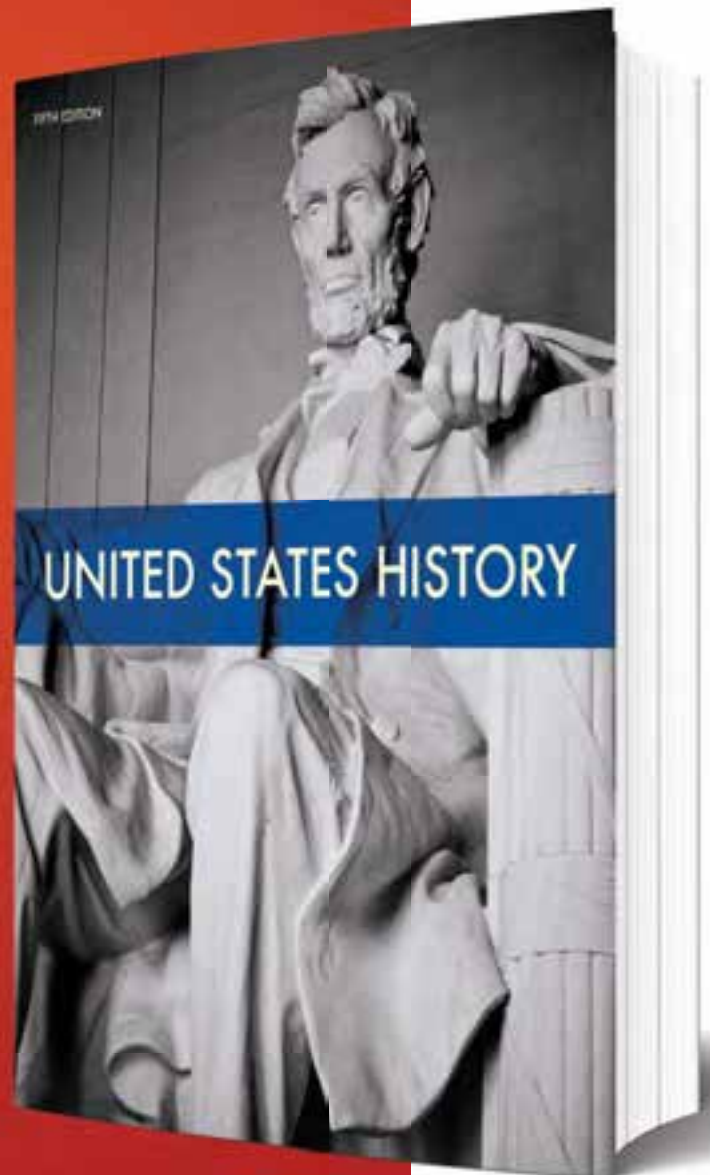

# Christian Classroom Online

## Streaming Video Classes for Your Needs

Use Christian Classroom Online video classes to support your school's curriculum offerings. Christian Classroom Online courses are pre-recorded video lessons led by experienced teachers available through video streaming. The interface allows the facilitator or individual student to easily navigate through daily lessons and access additional resources. Each course includes

- engaging, inspiring teachers who have a passion for their students, for Christ, and for their content,
- approximately 180 lessons with preset assignments,
- a variety of instructional strategies,
- support materials for facilitators,
- additional resources for expanding the material, and
- access to reproducible copies of ancillary student materials.



## Contact your Precept Sales Representative

at [preceptmarketing.com/rep](http://preceptmarketing.com/rep) or BJU Press customer service at 800.845.5731 to get started.

# New Courses for 2024

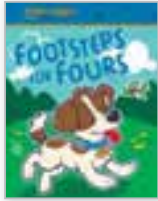

**Footsteps for Fours**  
(3rd ed.)



**Science 3** (5th ed.)



**Heritage Studies 3**  
(4th ed.)



**English 4** (3rd ed.)



**Math 6** (4th ed.)



**Literature 6** (3rd ed.)



**Life Science** (5th ed.)



**Cultural Geography**  
(5th ed.)



**Algebra 1** (4th ed.)

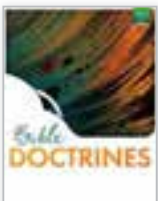

**Bible Doctrines**



**American Government**  
(4th ed.)

# Facilitator View

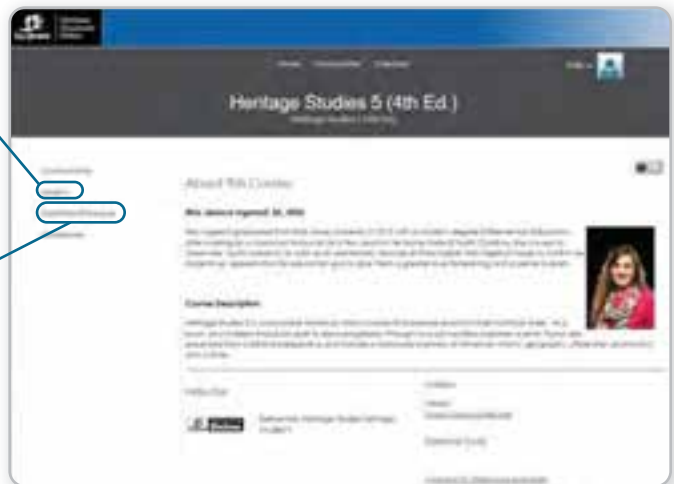
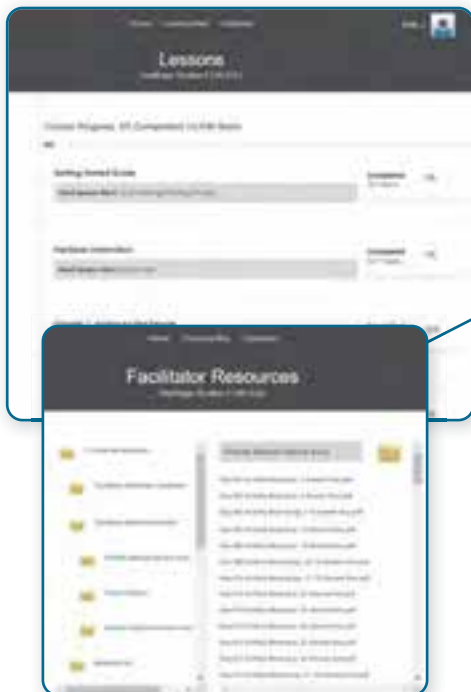

## Classroom License (Option 1)

A classroom license allows a single school facilitator to offer up to 8 courses. The facilitator presents the videos to each classroom, and the video directs the students' learning and assignments. The facilitator manages the classroom, supplies handouts, and grades assignments and tests.

### Option 1 Facilitator Login

The facilitator's account allows the facilitator to easily follow the planned video schedule. With Option 1, facilitators have access to PDF versions of teacher editions and materials produced by the CCO teacher of each course, including reproducible student handouts with answer keys, reproducible tests and quizzes with answer keys for Grades 5–12, a video lesson guide, and additional instructional aids.

### Benefits and Uses

- Includes courses you would not be able to offer in the absence of a qualified teacher
- Great resource for substitute teachers
- Teaching reference for new teachers or teaching a new course
- Offers quality instruction in a multi-grade classroom

*Some courses might use a previous edition textbook. Check the CCO Order Form pages for details.*

### COST

- \$169 for up to 8 courses (only one course may be viewed at a time)
- Separate purchase of required BJU Press student editions and worktexts, activities or lab manuals (all grades), and printed tests (Grades 1–4 only)
- Optional: preprinted CCO student handouts

### REPRODUCIBLE MATERIALS

- Grades 5–12 receive reproducible tests and quizzes in the facilitator resources
- Reproducible CCO student handouts available in facilitator resources

See order form on pages 121–27 for required printed materials.





## Individual Student License (Option 2)

Individual student registrations give the full benefit of Christian Classroom Online licenses. Students learn independently at their own pace from a passionate teacher whose video instruction is tailored to individual learners in a virtual environment. A facilitator will still need to be available to monitor students' progress, give assistance, grade assignments, and answer questions. Tests and quizzes can be taken online and automatically graded for Grades 5 and up. The facilitator will also have access to a complete online gradebook to generate reports or export grades to a different system.

### Option 2 Student and Facilitator Login

The learning management system makes it easy for the classroom facilitator and students with an individual license to navigate daily work and keep track of progress. Facilitators for Individual Student Licenses (Option 2) will enjoy access to digital teacher editions to assist students, auto-graded tests and quizzes (Grades 5–12), and activity reports to track each student's progress. Students can easily follow the planned video schedule and access associated eTextbooks.

### Benefits and Uses

- Credit recovery for new students
- Access to remote learning for students who need it
- Accommodate unique scheduling needs
- Offer quality instruction in a multi-grade classroom
- Online auto-graded tests and quizzes for Grades 5–12
- Included eTextbook for all nonconsumable textbooks for Grades 1–12

### COST

- Single student per course: \$89–\$119
- Single student per grade: \$229–\$569
- Purchase of required BJU Press worktexts, activities or lab manuals (all grades), and printed tests (Grades 1–4 only)
- Optional: printed textbooks for corresponding eTextbooks (see special pricing in the order form)
- Optional: preprinted CCO student handouts

See order form on pages 121–27 for required printed materials.

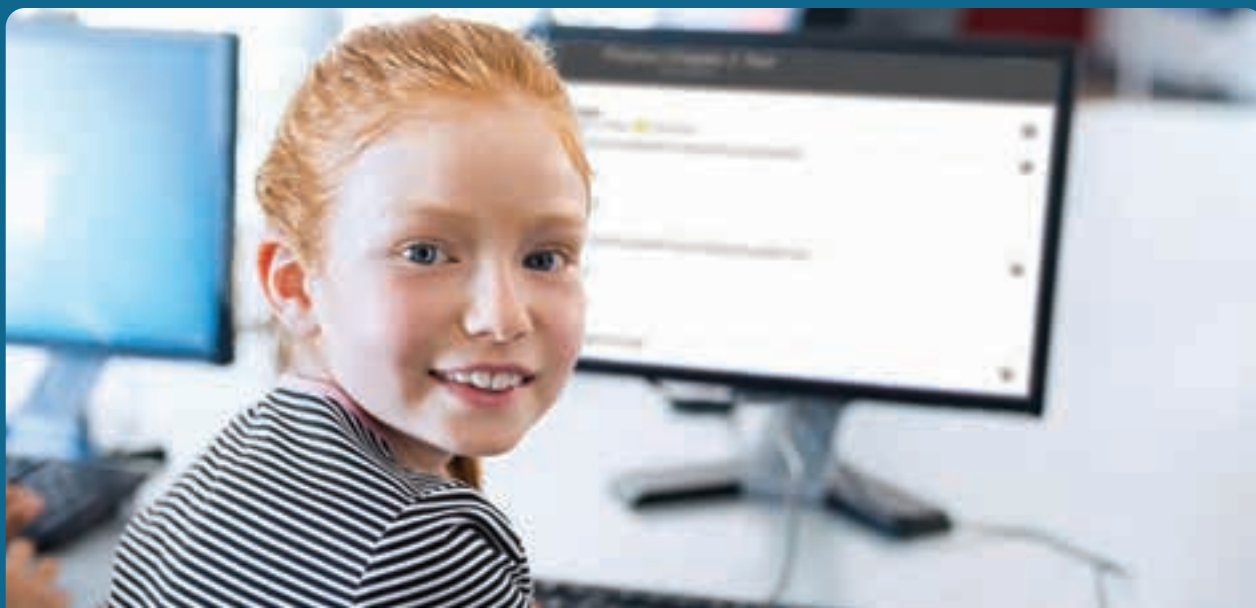



# Bring a Biblical Worldview into Your Classroom

## Biblical Worldview Formation in Education

(ED 275)

Are you looking for tools to improve biblical worldview shaping in your classroom? Dr. Bryan Smith's course, *Biblical Worldview Formation in Education*, helps Christian educators take the next step in making a biblical worldview central in their classrooms.



Dr. Bryan Smith, Director of Biblical Worldview at BJU Press, has created a course for Christian educators. This course meets the needs of Christian teachers who desire to improve their skills in biblical worldview formation.

In this course, you'll see how a biblical worldview is essential to each academic subject. You will also gain knowledge to create a classroom environment infused with a Christian philosophy of education.

### This class provides opportunities to:



Distinguish a secular approach from a Christian approach to education.



Develop a strategy for biblical worldview shaping in the classroom.



Design lesson plans that foster meaningful biblical integration in the classroom.



Evaluate Christian educational materials.



Write a personal Christian philosophy of education.



Earn CEU Credits.

Visit <https://www.bjupress.com/go/bwc> to learn more!

This regionally accredited course is offered online through BJU SCOPE Continuing & Professional Education.



# Christian School

## 2024 order form

Biblical Worldview • Critical Thinking • Technology Solutions • Academic Rigor

### Ordering Options

- Order online at [bjupress.com](http://bjupress.com).
- Order by phone from all states and Canada by calling 800.845.5731.
- Order by phone internationally by calling 864.770.1317.
  - Contact [international@bjupress.com](mailto:international@bjupress.com) for special shipping arrangements and customized assistance for international orders.

### Customer Information

(Please print clearly with black ink.)

- Established Account.** Please bill.
- New Account.** See credit terms, taxes, and delayed billing.

Account no. \_\_\_\_\_

Account name \_\_\_\_\_

Address \_\_\_\_\_

City \_\_\_\_\_ State \_\_\_\_\_ ZIP \_\_\_\_\_

Phone (        ) \_\_\_\_\_ Date \_\_\_\_\_

Fax (        ) \_\_\_\_\_

Email \_\_\_\_\_

Administrator \_\_\_\_\_

Your name \_\_\_\_\_

Signature \_\_\_\_\_

### Shipping Information

(if different from billing information)

Ship to \_\_\_\_\_

Address (not a PO box number) \_\_\_\_\_

City \_\_\_\_\_ State \_\_\_\_\_ ZIP \_\_\_\_\_

- Pickup order (See terms on page 100 for pickup information.)

### Method of Billing

- Regular Billing**
- Delayed Billing**  
See terms on page 100.
- Examination Billing**  
See terms on page 100.

Orders are not final until approved by BJU Press.

#### Office Use Only

Date \_\_\_\_\_ By \_\_\_\_\_

Attn. of \_\_\_\_\_

Pd. \$ \_\_\_\_\_ / \_\_\_\_\_ # \_\_\_\_\_

Payer ID # \_\_\_\_\_

Order # \_\_\_\_\_

- Ship to customer
- Distribution Center pickup

# Order Form

Name \_\_\_\_\_

Account No. \_\_\_\_\_

When faxing or mailing your order, be sure to include page 98.

**Phone: 800.845.5731**

**Fax: 800.525.8398**

**Email: [bjupinfo@bjupress.com](mailto:bjupinfo@bjupress.com)**

**Online: [bjupress.com](http://bjupress.com)**

## Orders Form/Write-In Worksheet

Mail, fax, or email your order with this page, or use these blanks to plan your purchase and then place your order by phone, by fax, or online.

Item Number	Qty.	Product Name	Price Each	Subtotal

**\*Special Note:** BJU Press will add the appropriate state and local sales/use tax to your order unless you have provided us with a copy of your tax-exemption certificate or, if the books are for resale, your resale certificate. In addition, BJU Press will bill you for shipping.

Total\*

Name \_\_\_\_\_

Account No. \_\_\_\_\_

When faxing or mailing your order, be sure to include page 98.

## Credit

The person who signs this order form or places an order with BJU Press by telephone authorizes the purchase and agrees to pay for the same under the following terms:

- **New Accounts:** To establish a new account, please enclose the name of your bank and the names, addresses, account numbers, and phone numbers of three companies with whom you have established credit. Include 25% of initial order as down payment.
- **Credit Terms:** All invoices are payable upon receipt and are due within 30 days. A service charge of 1.5% per month will be added to all balances due longer than 30 days.

**Note:** Delinquent accounts must be brought to current status before any additional orders will be processed. If collection is necessary, all collection fees are the responsibility of the purchaser.

- **Individuals:** Call 800.845.5731 for ordering information.
- **International Accounts:** Overseas accounts **must be prepaid** in United States funds. Add 40% for surface shipment (customer is responsible for loss or damage), or add 70% if air shipment is desired (\$30.00 minimum). We will bill the difference if actual shipping cost exceeds estimated amount. Please contact [international@bjupress.com](mailto:international@bjupress.com) for special shipping arrangements and other customized assistance.
- **Questions:** If you have questions about our credit policies, please call our credit department at 866.879.2966.

## Shipping

- **Any shipping discrepancies or damages must be reported within 10 days.**
- Transit times begin when the shipment leaves the shipping department. Should there be back-ordered items, we will ship them through our primary shipper whenever possible.
- All orders to Alaska, Hawaii, and most Trust Territories will be shipped Priority Mail through the postal service. Please allow extra time when ordering. However, expedited orders may be shipped by a priority service for an additional charge. Loss or damage of orders shipped book-rate will be the responsibility of the customer.
- We offer a separate shipping service to our Canadian customers. All product charges, including brokerage fees and taxes, will be included on one invoice. This service is available for orders that do not require freight transit. Loss or damage of orders shipped via U.S. mail are the responsibility of the customer.
- All orders will be processed when received. We cannot hold orders for a later shipping date.
- Local orders can be picked up at our distribution facility. Pickup orders are usually ready within 4 business days. An email will be sent to you indicating that your order is ready for pickup.

BJU Press Distribution Center  
134 White Oak Dr.  
Greenville, SC 29607-1218

## Delayed Billing

Orders received between April 1 and July 15, 2024, qualify for a September 1 invoice date, subject to the following terms:

- Orders must be at least \$1,000.
- Orders are placed on behalf of a conventional school.
- The school must request delayed billing at the time of ordering.
- Credit history of the school must be acceptable and the account current.
- The order will not be held for a later shipping date.

Delayed billing does not apply to Testing & Evaluation orders.

## Examination Policy

Contact your local Precept sales representative or call 800.845.5731 to order examination kits (review copies of textbook materials) with free shipping.

- Examination materials may be kept at no charge for 90 days (you will receive a temporary invoice).
- Pay for any items you wish to keep.
- Return remaining items in good salable condition to BJU Press within the 90-day examination period. Credit will be issued for returned items. Contact your Precept sales representative or customer service for a free return label.
- Examination copies are only available to conventional schools in the United States or its territories.
- The number of books available for examination is subject to approval.

**Please contact your regional Precept representative at [preceptmarketing.com/rep](mailto:preceptmarketing.com/rep) to request examination copies or extended periods.**

## Returns

Please ship all returns to the following address:

BJU Press Distribution Center  
134 White Oak Drive  
Greenville, SC 29607-1218

Books and materials may be returned subject to the following conditions:

- **The customer has contacted customer service to receive a return merchandise authorization (RMA) number.**
- Returns are made by the original purchaser.
- All returns (other than examination copies) will be assessed for a 10% restocking fee. Books returned **after** 90 days will be charged an additional 10% restocking fee then and for each additional month past the deadline. Refunds will not be issued on materials returned to us after 12 months from the shipping/invoice date. All unacceptable materials will be disposed of without credit.
- On the packing slip or invoice, please indicate items being returned and note the quantity of each item.
- Returns must be in good salable condition (undamaged and unmarked). We recommend all material be insured by your carrier of choice with a copy of the packing slip or invoice in each box.

Please call immediately should you receive defective or damaged materials. We will provide information about returning the items and obtaining replacements. Defective and damaged materials should be returned **within** 30 days of notifying BJU Press.

## Pricing

- **Prices are effective February 1, 2024, and are subject to change without notice.**
- Wholesale prices are available only to organizations, such as conventional schools, churches, and bookstores.
- Please remit in **United States** funds.

## Taxes

We must collect your **state and local** sales/use tax. Unless you have provided us with a copy of your tax-exemption or resale certificate, we will add your state and local sales/use tax (including sales/use tax on shipping charges in states where applicable). Tax-exempt orders must be paid by the tax-exempt organization (no personal checks or personal credit cards). Tax will not be credited after a sale. For questions, please contact our business office at 866.879.2966.



















































# Textbooks Order Form

Name \_\_\_\_\_

Account No. \_\_\_\_\_

When faxing or mailing your order, be sure to include page 98.

Item #	Qty.	List Price	Wholesale Price	Item #	Qty.	List Price	Wholesale Price
 546036		34.44	31.00	 548214		34.17	30.75
<b>512335</b>			<b>6.88</b>				
 548859			6.88	 547604		16.94	15.25
<b>Grade 5 The Fullness of Time</b>				<b>514604</b>			
For Teachers				<b>514604</b> Activities			
	515296	84.44	76.00	 547273		28.33	25.50
	515312	14.17	12.75	 546481		26.94	24.25
<b>For Students</b>				<b>514638</b> Assessments (assessments only; for 1 student)			
	515288	34.44	31.00	 548891			7.39
 546838		36.11	32.50	<b>Bible 9 Triumph of Christ</b>			
 546044		34.44	31.00	For Teachers			
<b>515304</b>			<b>6.88</b>		517185	52.22	47.00
 548867			6.88		517201	15.28	13.75
<b>Bible 6 Basics for a Biblical Worldview</b>					517177	22.78	20.50
For Teachers				<b>For Students</b>			
	517938	52.22	47.00	 517151		32.50	29.25
	517904	22.78	20.50	 548222		34.17	30.75
	517920	15.28	13.75	 547612		16.94	15.25
<b>For Students</b>				 517169		26.94	24.25
	517888	32.50	29.25	 547281		28.33	25.50
 548198		34.17	30.75	 546499		26.94	24.25
 547588		16.94	15.25	<b>517193</b>			<b>7.39</b>
<b>517896</b>		26.94	24.25	 548909			7.39
 546846		28.33	25.50	<b>Bible 10 Doctrines for a Biblical Worldview</b>			
 546051		26.94	24.25	For Teachers			
<b>517912</b>			<b>7.39</b>		521906	52.22	47.00
 548875			7.39		521930	15.28	13.75
<b>Bible 7 The Story of the Old Testament</b>					521955	22.78	20.50
For Teachers				<b>For Students</b>			
	512244	52.22	47.00	 521914		32.50	29.25
	512236	22.78	20.50	 548230		34.17	30.75
	512269	15.28	13.75	 547620		16.94	15.25
<b>For Students</b>				 521948		26.94	24.25
	512210	32.50	29.25	 547299		28.33	25.50
 548206		34.17	30.75	 546507		26.94	24.25
 547596		16.94	15.25	<b>521922</b>			<b>7.39</b>
<b>512228</b>		26.94	24.25	 548917			7.39
 547265		28.33	25.50	<b>Bible 11 Biblical Worldview (ESV)</b>			
 546473		26.94	24.25	For Teachers			
<b>512251</b>			<b>7.39</b>		296822	52.22	47.00
 548883			7.39		298760	15.28	13.75
<b>Bible 8 The Life of Christ</b>					503821	22.78	20.50
For Teachers				<b>For Students</b>			
	514620	52.22	47.00	 522979		32.50	29.25
	514646	15.28	13.75	 548248		34.17	30.75
	514612	22.78	20.50	 547638		16.94	15.25
<b>For Students</b>				 503813		26.94	24.25
	514596	32.50	29.25	 547307		28.33	25.50
				 546515		26.94	24.25
				<b>298745</b>			<b>47.00</b>
				 548925			7.39















Name \_\_\_\_\_

Account No. \_\_\_\_\_







When faxing or mailing your order, be sure to include page 98.

# Textbooks Order Form





Item #	Qty.	List Price	Wholesale Price
<b>Bible 11 Biblical Worldview (KJV)</b>			
For Teachers			
 297580	Teacher Edition (KJV)	52.22	47.00
298778	Assessments Answer Key (KJV)	15.28	13.75
506816	Activities Answer Key (KJV)	22.78	20.50
For Students			
516690	Student Edition (KJV)	32.50	29.25
 548255	eStudent Edition & Printed Student Edition	34.17	30.75
 547646	eStudent Edition	16.94	15.25
506808	Activities (KJV)	26.94	24.25
 547315	eActivities & Printed Student Activity	28.33	25.50
 546523	eActivities	26.94	24.25
298752	Assessments (KJV) (assessments only; for 1 student)	47.00	
 548933	eAssessments		7.39

Item #	Qty.	List Price	Wholesale Price
<b>Bible 12 Ethics <span style="background-color: green; color: white; padding: 2px;">NEW!</span></b>			
For Teachers			
 532952	Teacher Edition	52.22	47.00
532994	Assessments Answer Key	15.28	13.75
532978	Activities Answer Key	22.78	20.50
For Students			
532945	Student Edition	32.50	29.25
 548263	eStudent Edition & Printed Student Edition	34.17	30.75
 547653	eStudent Edition	16.94	15.25
532960	Activities	26.94	24.25
 547323	eActivities & Printed Student Activity	28.33	25.50
 546531	eActivities	26.94	24.25
532986	Assessments (assessments only; for 1 student)	21.11	7.39
 548941	eAssessments		7.39





## Science

Item #	Qty.	List Price	Wholesale Price
<b>Grade 1 Science (4th Edition)</b>			
For Teachers			
 508879	Teacher Edition	81.11	73.00
508846	Activities Answer Key	22.78	20.50
508895	Assessments Answer Key	14.17	12.75
For Students			
525550	Student Edition	56.67	51.00
 548651	eStudent Edition & Printed Student Edition	59.44	53.50
 548040	eStudent Edition	29.72	26.75
508838	Activities	38.33	34.50
 547141	eActivities & Printed Student Activity	40.28	36.25
 546358	eActivities	38.33	34.50
508887	Assessments (assessments only; for 1 student)	6.88	
 549337	eAssessments		6.88
526418	Grade 1 Logos Science Lab Kit	114.34	80.96





Item #	Qty.	List Price	Wholesale Price
<b>Grade 2 Science (5th Edition)</b>			
For Teachers			
 517664	Teacher Edition	81.11	73.00
517698	Activities Answer Key	22.78	20.50
517656	Assessments Answer Key	14.17	12.75

Item #	Qty.	List Price	Wholesale Price
<b>For Students</b>			
530089	Student Edition	56.67	51.00
 548669	eStudent Edition & Printed Student Edition	59.44	53.50
 548057	eStudent Edition	29.72	26.75
517680	Activities	38.33	34.50
 547158	eActivities & Printed Student Activity	40.28	36.25
 546366	eActivities	38.33	34.50
517649	Assessments (assessments only; for 1 student)	6.88	
 549345	eAssessments		6.88
535617	Grade 2 Logos Science Lab Kit	143.51	107.96

Item #	Qty.	List Price	Wholesale Price
<b>Grade 3 Science (5th Edition)</b>			
For Teachers			
 522599	Teacher Edition	81.11	73.00
522615	Activities Answer Key	22.78	20.50
522631	Assessments Answer Key	14.17	12.75

Item #	Qty.	List Price	Wholesale Price
<b>For Students</b>			
522581	Student Edition	56.67	51.00
 548677	eStudent Edition & Printed Student Edition	59.44	53.50
 548065	eStudent Edition	29.72	26.75
522607	Activities	38.33	34.50
 547166	eActivities & Printed Student Activity	40.28	36.25
 546374	eActivities	38.33	34.50
522623	Assessments (assessments only; for 1 student)	6.88	
 549352	eAssessments		6.88
526434	Grade 3 Logos Science Lab Kit	177.30	130.46

Item #	Qty.	List Price	Wholesale Price
<b>Grade 4 Science (5th Edition)</b>			
For Teachers			
 526517	Teacher Edition	81.11	73.00
526533	Activities Answer Key	22.78	20.50
526558	Assessments Answer Key	14.17	12.75

Item #	Qty.	List Price	Wholesale Price
<b>For Students</b>			
526509	Student Edition	56.67	51.00
 548685	eStudent Edition & Printed Student Edition	59.44	53.50
 548073	eStudent Edition	29.72	26.75
526525	Activities	38.33	34.50
 547174	eActivities & Printed Student Activity	40.28	36.25
 546382	eActivities	38.33	34.50
526541	Assessments (assessments only; for 1 student)	6.88	
 549360	eAssessments		6.88
538942	Grade 4 Logos Science Lab Kit	198.50	178.65

Item #	Qty.	List Price	Wholesale Price
<b>Grade 5 Science (4th Edition)</b>			
For Teachers			
 293001	Teacher Edition	81.11	73.00
507509	Activities Answer Key	22.78	20.50
293043	Assessments Answer Key	14.17	12.75



Item #	Qty.	List Price	Wholesale Price
<b>For Students</b>			
522425	Student Edition	56.67	51.00
 548693	eStudent Edition & Printed Student Edition	59.44	53.50
 548081	eStudent Edition	29.72	26.75
293019	Activities	38.33	34.50

# Textbooks Order Form

Name \_\_\_\_\_

Account No. \_\_\_\_\_

When faxing or mailing your order, be sure to include page 98.





Item #	Qty.	List Price	Wholesale Price
 547182	_____	eActivities & Printed Student Activity	40.28 36.25
 546390	_____	eActivities	38.33 34.50
<b>293027</b>	_____	<b>Assessments (assessments only; for 1 student)</b>	<b>6.88</b>
 549378	_____	eAssessments	6.88
526459	_____	Grade 5 Logos Science Lab Kit	177.27 159.55

## Grade 6 Science (4th Edition)

For Teachers

 281311	_____	Teacher Edition	81.11 73.00
507517	_____	Activities Answer Key	22.78 20.50
281352	_____	Assessments Answer Key	14.17 12.75

For Students





<b>522391</b>	_____	<b>Student Edition</b>	<b>56.67 51.00</b>
 548701	_____	eStudent Edition & Printed Student Edition	59.44 53.50
 548099	_____	eStudent Edition	29.72 26.75
<b>281329</b>	_____	<b>Activities</b>	<b>38.33 34.50</b>
 547190	_____	eActivities & Printed Student Activity	40.28 36.25
 546408	_____	eActivities	38.33 34.50
<b>281345</b>	_____	<b>Assessments (assessments only; for 1 student)</b>	<b>6.88</b>
 549386	_____	eAssessments	6.88
526467	_____	Grade 6 Logos Science Lab Kit	172.81 121.46

## Grade 7 Life Science (5th Edition)

For Teachers

 513085	_____	Teacher Edition (2 vols.)	95.28 85.75
513069	_____	Activities Answer Key	44.44 40.00
513119	_____	Assessments Answer Key	15.28 13.75
107789	_____	Life Science Slides	104.50

For Students





<b>513051</b>	_____	<b>Student Edition</b>	<b>86.11 77.50</b>
 548719	_____	eStudent Edition & Printed Student Edition	90.56 81.50
 548107	_____	eStudent Edition	45.28 40.75
<b>513077</b>	_____	<b>Activities</b>	<b>38.33 34.50</b>
 547497	_____	eActivities & Printed Student Activity	40.28 36.25
 546705	_____	eActivities	38.33 34.50
<b>513101</b>	_____	<b>Assessments (assessments only; for 1 student)</b>	<b>7.39</b>
 549394	_____	eAssessments	7.39
517094	_____	Life Science Logos Science Lab Kit	248.53 197.96
517102	_____	Life Science Logos Science Lab Refill Kit	88.33 53.96

## Grade 8 Earth Science (5th Edition)

For Teachers

 508697	_____	Teacher Edition (2 vols.)	95.28 85.75
508671	_____	Lab Manual Teacher Edition	44.44 40.00
508721	_____	Assessments Answer Key	15.28 13.75

For Students

<b>508655</b>	_____	<b>Student Edition</b>	<b>86.11 77.50</b>
 548727	_____	eStudent Edition & Printed Student Edition	90.56 81.50
 548115	_____	eStudent Edition	45.28 40.75
<b>508663</b>	_____	<b>Student Lab Manual</b>	<b>38.33 34.50</b>
 547505	_____	eLab & Printed Student Lab	40.28 36.25
 546713	_____	eLab	38.33 34.50





Item #	Qty.	List Price	Wholesale Price
<b>508713</b>	_____	<b>Assessments (assessments only; for 1 student)</b>	<b>7.39</b>
 549402	_____	eAssessments	7.39
514745	_____	Earth Science Logos Science Lab Kit	260.86 206.96
514752	_____	Earth Science Logos Science Lab Refill Kit	58.62 40.46

## Grade 9 Physical Science (6th Edition)

For Teachers

 515460	_____	Teacher Edition (2 vols.)	95.28 85.75
515502	_____	Teacher Lab Manual	44.44 40.00
515528	_____	Assessments Answer Key	15.28 13.75

For Students





<b>515437</b>	_____	<b>Student Edition</b>	<b>86.11 77.50</b>
 548735	_____	eStudent Edition & Printed Student Edition	90.56 81.50
 548123	_____	eStudent Edition	45.28 40.75
<b>515494</b>	_____	<b>Student Lab Manual</b>	<b>38.33 34.50</b>
 547513	_____	eLab & Printed Student Lab	40.28 36.25
 546721	_____	eLab	38.33 34.50
<b>515510</b>	_____	<b>Assessments (assessments only; for 1 student)</b>	<b>7.39</b>
 549410	_____	eAssessments	7.39
522706	_____	Physical Science Logos Science Lab Kit	422.04 341.96

## Grade 10 Biology (6th Edition) **NEW!**

For Teachers

 528786	_____	Teacher Edition	95.28 85.75
528802	_____	Lab Manual Teacher Edition	44.44 40.00
528828	_____	Assessments Answer Key	15.28 13.75
276576	_____	Biology Dissection Kit (Grades 7, 10)	80.25
033076	_____	Biology Specimen Replacements for Dissection Kit (Grades 7, 10)	20.25

For Students





<b>528778</b>	_____	<b>Student Edition</b>	<b>86.11 77.50</b>
 548743	_____	eStudent Edition & Printed Student Edition	90.56 81.50
 548131	_____	eStudent Edition	45.28 40.75
<b>528794</b>	_____	<b>Student Lab Manual</b>	<b>38.33 34.50</b>
 547521	_____	eLab & Printed Student Lab	40.28 36.25
 546739	_____	eLab	38.33 34.50
<b>528810</b>	_____	<b>Assessments (assessments only; for 1 student)</b>	<b>7.39</b>
 549428	_____	eAssessments	7.39
544031	_____	Biology Logos Science Lab Kit	check online
544049	_____	Biology Logos Science Lab Refill Kit	check online

## Grade 11 Chemistry (5th Edition)

For Teachers

 519769	_____	Teacher Edition (2 vols.)	95.28 85.75
519785	_____	Lab Manual Teacher Edition	44.44 40.00
519801	_____	Assessments Answer Key	15.28 13.75

For Students

<b>519751</b>	_____	<b>Student Edition</b>	<b>86.11 77.50</b>
 548750	_____	eStudent Edition & Printed Student Edition	90.56 81.50
 548149	_____	eStudent Edition	45.28 40.75
<b>519777</b>	_____	<b>Student Lab Manual</b>	<b>38.33 34.50</b>
 547539	_____	eLab & Printed Student Lab	40.28 36.25
 546747	_____	eLab	38.33 34.50

Name \_\_\_\_\_

Account No. \_\_\_\_\_

When faxing or mailing your order, be sure to include page 98.

# Textbooks Order Form

Item #	Qty.	List Price	Wholesale Price
<b>519793</b>			<b>7.39</b>
 549436		7.39	
526335		357.24	292.46
526343		76.35	40.46





## Grade 12 Physics (4th Edition)

For Teachers



<b>500652</b>		<b>95.28</b>	<b>85.75</b>
<b>500645</b>		<b>44.44</b>	<b>40.00</b>
<b>500694</b>		<b>15.28</b>	<b>13.75</b>

For Students

<b>295774</b>		<b>86.11</b>	<b>77.50</b>
 548768		90.56	81.50
 548156		45.28	40.75
<b>500637</b>		<b>38.33</b>	<b>34.50</b>
 547547		40.28	36.25
 546754		38.33	34.50
<b>500686</b>		<b>7.39</b>	
 549444		7.39	
538959			441.63

## Heritage Studies





### Grade 1 Family and Community (4th Edition)

For Teachers



<b>517433</b>		<b>81.11</b>	<b>73.00</b>
<b>517425</b>		<b>22.78</b>	<b>20.50</b>
<b>517466</b>		<b>14.17</b>	<b>12.75</b>
044180		15.00	

For Students

<b>530915</b>		<b>52.22</b>	<b>47.00</b>
 548271		54.72	49.25
 547661		27.50	24.75
<b>517417</b>		<b>36.39</b>	<b>32.75</b>
 546929		38.33	34.50
 546135		36.39	32.75
<b>517458</b>		<b>6.88</b>	
 548958		6.88	



### Grade 2 Community and Government (4th Edition)



For Teachers



<b>520783</b>		<b>81.11</b>	<b>73.00</b>
<b>520809</b>		<b>22.78</b>	<b>20.50</b>
<b>520825</b>		<b>14.17</b>	<b>12.75</b>
044180		15.00	

For Students

<b>520775</b>		<b>52.22</b>	<b>47.00</b>
 548289		54.72	49.25
 547679		27.50	24.75
<b>520791</b>		<b>36.39</b>	<b>32.75</b>
 546937		38.33	34.50

Item #	Qty.	List Price	Wholesale Price
 546143		36.39	32.75
<b>520817</b>			<b>6.88</b>
 548966			6.88





## Grade 3 World Regions (4th Edition)

For Teachers



<b>526657</b>		<b>81.11</b>	<b>73.00</b>
<b>526673</b>		<b>22.78</b>	<b>20.50</b>
<b>526699</b>		<b>14.17</b>	<b>12.75</b>
044180		15.00	

For Students

<b>526640</b>		<b>52.22</b>	<b>47.00</b>
 548297		54.72	49.25
 547687		27.50	24.75
<b>526665</b>		<b>36.39</b>	<b>32.75</b>
 546945		38.33	34.50
 546150		36.39	32.75
<b>526681</b>		<b>6.88</b>	
 548974		6.88	





## Grade 4 Heritage Studies (4th Edition) **NEW!**

For Teachers



<b>535369</b>		<b>81.11</b>	<b>73.00</b>
<b>535393</b>		<b>22.78</b>	<b>20.50</b>
<b>535419</b>		<b>14.17</b>	<b>12.75</b>
044180		15.00	

For Students

<b>535377</b>		<b>52.22</b>	<b>47.00</b>
 548305		54.72	49.25
 547695		27.50	24.75
<b>535385</b>		<b>36.39</b>	<b>32.75</b>
 546952		38.33	34.50
 546168		36.39	32.75
<b>535401</b>		<b>6.88</b>	
 548982		6.88	





## Grade 5 Heritage Studies (4th Edition)

For Teachers



<b>500363</b>		<b>81.11</b>	<b>73.00</b>
<b>507400</b>		<b>22.78</b>	<b>20.50</b>
<b>500405</b>		<b>14.17</b>	<b>12.75</b>
044180		15.00	

For Students















































<b>536078</b>		<b>52.22</b>	<b>47.00</b>
 548313		54.72	49.25
 547703		27.50	24.75
<b>500371</b>		<b>36.39</b>	<b>32.75</b>
 546960		38.33	34.50
 546176		36.39	32.75
<b>500389</b>		<b>6.88</b>	
 548990		6.88	

# Textbooks Order Form

Name \_\_\_\_\_

Account No. \_\_\_\_\_

When faxing or mailing your order, be sure to include page 98.

Item #	Qty.	List Price	Wholesale Price	Item #	Qty.	List Price	Wholesale Price
<b>Grade 6 Heritage Studies (4th Edition)</b>				<b>For Students</b>			
<b>For Teachers</b>				<b>518746 Student Edition 77.22 69.50</b>			
 506634		81.11	73.00	 548354		81.11	73.00
506600		22.78	20.50	 547745		40.56	36.50
506659		14.17	12.75	<b>518761 Activities 42.22 38.00</b>			
044180		15.00		 547414		44.44	40.00
				 546622		42.22	38.00
044172		17.25		<b>518787 Assessments (assessments only; for 1 student) 7.39</b>			
				 549030			7.39
<b>For Students</b>				<b>Grade 10 World History (5th Edition)</b>			
<b>520007 Student Edition 52.22 47.00</b>				<b>For Teachers</b>			
 548321		54.72	49.25	 <b>512749 Teacher Edition (2 vols.) 96.39 86.75</b>			
 547711		27.50	24.75	 <b>512731 Activities Answer Key 47.78 43.00</b>			
<b>506592 Activities 36.39 32.75</b>				 <b>512756 Assessments Answer Key 15.28 13.75</b>			
 546978		38.33	34.50	<b>For Students</b>			
 546184		36.39	32.75	<b>512293 Student Edition 77.22 69.50</b>			
<b>506642 Assessments (assessments only; for 1 student) 6.88</b>				 548362		81.11	73.00
 549006			6.88	 547752		40.56	36.50
<b>Grade 7 World Studies (5th Edition)</b>				<b>512723 Activities 42.22 38.00</b>			
<b>For Teachers</b>				 547422		44.44	40.00
 <b>526228 Teacher Edition 96.39 86.75</b>				 546630		42.22	38.00
<b>526244 Activities Answer Key 47.78 43.00</b>				<b>512764 Assessments (assessments only; for 1 student) 7.39</b>			
<b>526269 Assessments Answer Key 15.28 13.75</b>				 549048			7.39
<b>For Students</b>				<b>Grade 11 United States History (5th Edition)</b>			
<b>526210 Student Edition 77.22 69.50</b>				<b>For Teachers</b>			
 548339		81.11	73.00	 <b>506717 Teacher Edition (2 vols.) 96.39 86.75</b>			
 547729		40.56	36.50	 <b>506683 Activities Answer Key 47.78 43.00</b>			
<b>526236 Activities 42.22 38.00</b>				 <b>506733 Assessments Answer Key 15.28 13.75</b>			
 547398		44.44	40.00	<b>For Students</b>			
 546606		42.22	38.00	<b>505776 Student Edition 77.22 69.50</b>			
<b>526251 Assessments (assessments only; for 1 student) 7.39</b>				 548370		81.11	73.00
 549014			7.39	 547760		40.56	36.50
<b>Grade 8 The American Republic (5th Edition)</b>				<b>506675 Activities 42.22 38.00</b>			
<b>For Teachers</b>				 547430		44.44	40.00
 <b>522789 Teacher Edition (2 vols.) 96.39 86.75</b>				 546648		42.22	38.00
<b>522805 Activities Answer Key 47.78 43.00</b>				<b>506725 Assessments (assessments only; for 1 student) 7.39</b>			
<b>522821 Assessments Answer Key 15.28 13.75</b>				 549055			7.39
<b>For Students</b>				<b>Grade 12 American Government (4th Edition)</b>			
<b>522771 Student Edition 77.22 69.50</b>				<b>For Teachers</b>			
 548347		81.11	73.00	 <b>516526 Teacher Edition 96.39 86.75</b>			
 547737		40.56	36.50	 <b>516559 Activities Answer Key 47.78 43.00</b>			
<b>522797 Activities 42.22 38.00</b>				 <b>516534 Assessments Answer Key 15.28 13.75</b>			
 547406		44.44	40.00	<b>For Students</b>			
 546614		42.22	38.00	<b>513523 Student Edition 68.61 61.75</b>			
<b>522813 Assessments (assessments only; for 1 student) 7.39</b>				 548396		71.94	64.75
 549022			7.39	 547786		36.11	32.50
<b>Grade 9 Cultural Geography (5th Edition)</b>				<b>516518 Activities 39.72 35.75</b>			
<b>For Teachers</b>				 547448		41.67	37.50
 <b>518753 Teacher Edition (2 vols.) 96.39 86.75</b>				 546655		39.72	35.75
<b>518779 Activities Answer Key 47.78 43.00</b>							
<b>518795 Assessments Answer Key 15.28 13.75</b>							

Name \_\_\_\_\_

Account No. \_\_\_\_\_

When faxing or mailing your order, be sure to include page 98.

# Textbooks Order Form





Item #	Qty.	List Price	Wholesale Price
<b>516542</b>	_____	<b>Assessments (assessments only; for 1 student)</b>	<b>7.39</b>
 549071	_____	eAssessments	7.39

## Grade 12 Economics (3rd Edition)

For Teachers

 <b>500553</b>	_____	<b>Teacher Edition</b>	<b>96.39</b>	<b>86.75</b>
<b>500579</b>	_____	<b>Activities Answer Key</b>	<b>47.78</b>	<b>43.00</b>
<b>500595</b>	_____	<b>Assessments Answer Key</b>	<b>15.28</b>	<b>13.75</b>

For Students

<b>517086</b>	_____	<b>Student Edition</b>	<b>68.61</b>	<b>61.75</b>
 548388	_____	eStudent Edition & Printed Student Edition	71.94	64.75
 547778	_____	eStudent Edition	36.11	32.50
<b>500561</b>	_____	<b>Activities</b>	<b>39.72</b>	<b>35.75</b>
 547455	_____	eActivities & Printed Student Activity	41.67	37.50
 546663	_____	eActivities	39.72	35.75
<b>500587</b>	_____	<b>Assessments (assessments only; for 1 student)</b>	<b>7.39</b>	
 549063	_____	eAssessments		7.39

## Heritage Studies Resources

001768	_____	<i>American History in Verse</i> , Stevenson (Grades 7–12)	11.00	
056861	_____	<i>Faith of Our Fathers: Scenes from American Church History</i> , Sidwell (Grades 7–12)	13.00	
046441	_____	<i>Faith of Our Fathers: Scenes from Church History</i> , Sidwell (Grades 7–12)	12.00	
044172	_____	<i>Historical Atlas of the World</i> (softbound; Rand McNally; Grades 1–6)	17.25	

## Math

### K5 Math (4th Edition)

For Teachers

 <b>286674</b>	_____	<b>Teacher Edition</b>	<b>98.33</b>	<b>88.50</b>
<b>286682</b>	_____	<b>Visual Packet</b>	<b>93.33</b>	<b>84.00</b>

For Students





<b>522433</b>	_____	<b>Student Worktext</b>	<b>34.44</b>	<b>31.00</b>
<b>286690</b>	_____	<b>Student Manipulatives Packet (Grades K5–1)</b>	<b>23.89</b>	<b>21.50</b>

### Grade 1 Math (5th Edition) **NEW!**

For Teachers

 <b>532853</b>	_____	<b>Teacher Edition</b>	<b>98.33</b>	<b>88.50</b>
<b>532820</b>	_____	<b>Reviews Key</b>	<b>22.78</b>	<b>20.50</b>
<b>532861</b>	_____	<b>Visual Packet</b>	<b>93.33</b>	<b>84.00</b>
<b>532846</b>	_____	<b>Assessment Key</b>	<b>14.17</b>	<b>12.75</b>
204610	_____	<i>Backyard Math with Zac</i> DVD Set (2 DVDs; 180 min.; Grade 1)	19.95	

For Students

<b>532804</b>	_____	<b>Student Worktext</b>	<b>39.72</b>	<b>35.75</b>
 546986	_____	eWorktext & Printed Student Worktext	41.67	37.50
 546192	_____	eWorktext	39.72	35.75
<b>532812</b>	_____	<b>Reviews</b>	<b>15.00</b>	<b>13.50</b>
 546994	_____	eReview & Printed Student Review	15.83	14.25
 546200	_____	eReview	15.00	13.50





Item #	Qty.	List Price	Wholesale Price	
<b>532879</b>	_____	<b>Student Manipulatives</b>	<b>23.89</b>	<b>21.50</b>
<b>532838</b>	_____	<b>Assessments (assessments only; for 1 student)</b>		<b>6.88</b>
 549170	_____	eAssessments		6.88

### Grade 2 Math (4th Edition)

For Teachers

 <b>512830</b>	_____	<b>Teacher Edition</b>	<b>98.33</b>	<b>88.50</b>
<b>507434</b>	_____	<b>Reviews Answer Key</b>	<b>22.78</b>	<b>20.50</b>
<b>299727</b>	_____	<b>Visual Packet</b>	<b>93.33</b>	<b>84.00</b>
<b>512822</b>	_____	<b>Assessments Answer Key</b>	<b>14.17</b>	<b>12.75</b>

For Students





<b>539379</b>	_____	<b>Student Worktext</b>	<b>39.72</b>	<b>35.75</b>
 547000	_____	eWorktext & Printed Student Worktext	41.67	37.50
 546218	_____	eWorktext	39.72	35.75
<b>299735</b>	_____	<b>Math 2 Reviews</b>	<b>15.00</b>	<b>13.50</b>
 547018	_____	eReview & Printed Student Review	15.83	14.25
 546226	_____	eReview	15.00	13.50
<b>299719</b>	_____	<b>Student Manipulatives Packet</b>	<b>23.89</b>	<b>21.50</b>
<b>512814</b>	_____	<b>Assessments (assessments only; for 1 student)</b>		<b>6.88</b>
 549188	_____	eAssessments		6.88

### Grade 3 Math (4th Edition)

For Teachers

 <b>506410</b>	_____	<b>Teacher Edition</b>	<b>98.33</b>	<b>88.50</b>
<b>509000</b>	_____	<b>Reviews Answer Key</b>	<b>22.78</b>	<b>20.50</b>
<b>506469</b>	_____	<b>Visual Packet</b>	<b>93.33</b>	<b>84.00</b>
<b>506436</b>	_____	<b>Assessments Answer Key</b>	<b>14.17</b>	<b>12.75</b>

For Students





<b>506493</b>	_____	<b>Student Worktext</b>	<b>39.72</b>	<b>35.75</b>
 547026	_____	eWorktext & Printed Student Worktext	41.67	37.50
 546234	_____	eWorktext	39.72	35.75
<b>506451</b>	_____	<b>Student Manipulatives Packet</b>	<b>23.89</b>	<b>21.50</b>
<b>506444</b>	_____	<b>Math 3 Reviews</b>	<b>15.00</b>	<b>13.50</b>
 547034	_____	eReview & Printed Student Review	15.83	14.25
 546242	_____	eReview	15.00	13.50
<b>506428</b>	_____	<b>Assessments (assessments only; for 1 student)</b>		<b>6.88</b>
 549196	_____	eAssessments		6.88

### Grade 4 Math (4th Edition)

For Teachers

 <b>515593</b>	_____	<b>Teacher Edition</b>	<b>98.33</b>	<b>88.50</b>
<b>515551</b>	_____	<b>Visual Packet</b>	<b>68.61</b>	<b>61.75</b>
<b>515601</b>	_____	<b>Activities Answer Key</b>	<b>22.78</b>	<b>20.50</b>
<b>515619</b>	_____	<b>Assessments Answer Key</b>	<b>14.17</b>	<b>12.75</b>

For Students

<b>515536</b>	_____	<b>Student Worktext</b>	<b>39.72</b>	<b>35.75</b>
 547042	_____	eWorktext & Printed Student Worktext	41.67	37.50
 546259	_____	eWorktext	39.72	35.75
<b>515544</b>	_____	<b>Student Manipulatives Packet</b>	<b>23.89</b>	<b>21.50</b>
<b>515585</b>	_____	<b>Activities</b>	<b>15.00</b>	<b>13.50</b>
 547059	_____	eActivities & Printed Student Activity	15.83	14.25
 546267	_____	eActivities	15.00	13.50
<b>515569</b>	_____	<b>Assessments (assessments only; for 1 student)</b>		<b>6.88</b>

# Textbooks Order Form

Name \_\_\_\_\_

Account No. \_\_\_\_\_

When faxing or mailing your order, be sure to include page 98.

Item #	Qty.	List Price	Wholesale Price
549204	_____	eAssessments	6.88
<b>Grade 5 Math (4th Edition)</b>			
For Teachers			
518910	_____	Teacher Edition (2 vols.)	<b>98.33 88.50</b>
518936	_____	Assessments Answer Key	<b>14.17 12.75</b>
For Students			
518894	_____	Student Worktext	<b>39.72 35.75</b>
547067	_____	eWorktext & Printed Student Worktext	41.67 37.50
546275	_____	eWorktext	39.72 35.75
518902	_____	Activities	<b>15.00 13.50</b>
547075	_____	eActivities & Printed Student Activity	15.83 14.25
546283	_____	eActivities	15.00 13.50
518928	_____	Assessments (assessments only; for 1 student)	<b>6.88</b>
549212	_____	eAssessments	6.88

<b>Grade 6 Math (4th Edition)</b>			
For Teachers			
525451	_____	Teacher Edition (2 vols.)	<b>106.94 96.25</b>
525477	_____	Assessments Answer Key	<b>15.28 13.75</b>
For Students			
525444	_____	Student Edition	<b>71.94 64.75</b>
548404	_____	eStudent Edition & Printed Student Edition	75.56 68.00
547794	_____	eStudent Edition	37.78 34.00
525469	_____	Assessments (assessments only; for 1 student)	<b>7.39</b>
549220	_____	eAssessments	7.39

<b>Grade 7 Fundamentals of Math (3rd Edition)</b>			
For Teachers			
522284	_____	Teacher Edition (2 vols.)	<b>106.94 96.25</b>
522300	_____	Activities Answer Key	<b>50.00 45.00</b>
522326	_____	Assessments Answer Key	<b>15.28 13.75</b>
For Students			
522276	_____	Student Edition	<b>71.94 64.75</b>
548412	_____	eStudent Edition & Printed Student Edition	75.56 68.00
547802	_____	eStudent Edition	37.78 34.00
522292	_____	Activities	<b>25.28 22.75</b>
547463	_____	eActivities & Printed Student Activity	26.67 24.00
546671	_____	eActivities	25.28 22.75
522318	_____	Assessments (assessments only; for 1 student)	<b>7.39</b>
549238	_____	eAssessments	7.39

<b>Grade 8 Pre-Algebra (3rd Edition)</b>			
For Teachers			
525097	_____	Teacher Edition	<b>106.94 96.25</b>
525113	_____	Activities Answer Key	<b>50.00 45.00</b>
525139	_____	Assessments Answer Key	<b>15.28 13.75</b>
For Students			
525089	_____	Student Edition	<b>71.94 64.75</b>
548420	_____	eStudent Edition & Printed Student Edition	75.56 68.00
547810	_____	eStudent Edition	37.78 34.00

525105	_____	Activities	<b>25.28 22.75</b>
547471	_____	eActivities & Printed Student Activity	26.67 24.00
546689	_____	eActivities	25.28 22.75
525121	_____	Assessments (assessments only; for 1 student)	<b>7.39</b>
549246	_____	eAssessments	7.39

<b>Grade 9 Algebra 1 (4th Edition) <span style="background-color: green; color: white; padding: 2px;">NEW!</span></b>			
For Teachers			
537068	_____	Teacher Edition	<b>106.94 96.25</b>
537092	_____	Activities Manual Answer Key	<b>50.00 45.00</b>
537118	_____	Assessments Answer Key	<b>15.28 13.75</b>
For Students			
537076	_____	Student Edition	<b>71.94 64.75</b>
548438	_____	eStudent Edition & Printed Student Edition	75.56 68.00
547828	_____	eStudent Edition	37.78 34.00
537084	_____	Activities Manual	<b>25.28 22.75</b>
547489	_____	eActivities & Printed Student Activity	26.67 24.00
546697	_____	eActivities	25.28 22.75
537100	_____	Assessments (assessments only; for 1 student)	<b>7.39</b>
549253	_____	eAssessments	7.39

<b>Grade 10 Geometry (4th Edition)</b>			
For Teachers			
299123	_____	Teacher Edition (2 vols.)	<b>106.94 96.25</b>
299156	_____	Assessments Answer Key	<b>15.28 13.75</b>
For Students			
515858	_____	Student Edition	<b>71.94 64.75</b>
548446	_____	eStudent Edition & Printed Student Edition	75.56 68.00
547836	_____	eStudent Edition	37.78 34.00
299131	_____	Assessments (assessments only; for 1 student)	<b>7.39</b>
549261	_____	eAssessments	7.39

<b>Grade 11 Algebra 2 (3rd Edition)</b>			
For Teachers			
286401	_____	Teacher Edition (2 vols.)	<b>106.94 96.25</b>
286435	_____	Assessments Answer Key	<b>15.28 13.75</b>
For Students			
515783	_____	Student Edition	<b>71.94 64.75</b>
548453	_____	eStudent Edition & Printed Student Edition	75.56 68.00
547844	_____	eStudent Edition	37.78 34.00
286419	_____	Assessments (assessments only; for 1 student)	<b>7.39</b>
549279	_____	eAssessments	7.39



<b>Grade 12 Precalculus (2nd Edition)</b>			
For Teachers			
511485	_____	Teacher Edition (2 vols.)	<b>106.94 96.25</b>
511501	_____	Assessments Answer Key	<b>15.28 13.75</b>
For Students			
299974	_____	Student Edition	<b>71.94 64.75</b>
548461	_____	eStudent Edition & Printed Student Edition	75.56 68.00

Name \_\_\_\_\_

Account No. \_\_\_\_\_

When faxing or mailing your order, be sure to include page 98.

# Textbooks Order Form

Item #	Qty.	List Price	Wholesale Price
 547851	_____	37.78	34.00
<b>511493</b>	_____	<b>7.39</b>	<b>7.39</b>
 549287	_____	7.39	7.39



### Grades 11–12 Consumer Math (3rd Edition)

For Teachers



<b>518605</b>	_____	<b>98.33</b>	<b>88.50</b>
<b>518621</b>	_____	<b>15.28</b>	<b>13.75</b>

For Students

<b>518597</b>	_____	<b>71.94</b>	<b>64.75</b>
 548479	_____	75.56	68.00
 547869	_____	37.78	34.00
<b>518613</b>	_____	<b>7.39</b>	<b>7.39</b>
 549295	_____	7.39	7.39

## English/Writing & Grammar

See Reading 1 and Spelling 1 for a complete phonics package.





### Grade 1 Phonics & English (5th Edition) **NEW!**

For Teachers



<b>535633</b>	_____	<b>108.61</b>	<b>97.75</b>
<b>535708</b>	_____	<b>27.78</b>	<b>25.00</b>
<b>535922</b>	_____	<b>27.78</b>	<b>25.00</b>
<b>535930</b>	_____	<b>96.39</b>	<b>86.75</b>

For Students

<b>535641</b>	_____	<b>43.33</b>	<b>39.00</b>
 546853	_____	45.56	41.00
 546069	_____	43.33	39.00
<b>535658</b>	_____	<b>36.11</b>	<b>32.50</b>
 546861	_____	38.06	34.25
 546077	_____	36.11	32.50



### Grade 2 English (3rd Edition)

For Teachers



<b>501668</b>	_____	<b>89.17</b>	<b>80.25</b>
<b>501718</b>	_____	<b>14.17</b>	<b>12.75</b>

For Students

<b>501452</b>	_____	<b>36.11</b>	<b>32.50</b>
 546879	_____	38.06	34.25
 546085	_____	36.11	32.50
<b>501692</b>	_____	<b>6.88</b>	<b>6.88</b>
 549451	_____	6.88	6.88

### Grade 3 English (3rd Edition)



For Teachers



<b>517581</b>	_____	<b>89.17</b>	<b>80.25</b>
<b>517607</b>	_____	<b>14.17</b>	<b>12.75</b>

For Students

<b>517573</b>	_____	<b>36.11</b>	<b>32.50</b>
 546887	_____	38.06	34.25

Item #	Qty.	List Price	Wholesale Price
 546093	_____	36.11	32.50
<b>517599</b>	_____	<b>6.88</b>	<b>6.88</b>
 549469	_____	6.88	6.88



### Grade 4 English (3rd Edition)

For Teachers



<b>522904</b>	_____	<b>89.17</b>	<b>80.25</b>
<b>522920</b>	_____	<b>14.17</b>	<b>12.75</b>

For Students

<b>522896</b>	_____	<b>36.11</b>	<b>32.50</b>
 546895	_____	38.06	34.25
 546101	_____	36.11	32.50
<b>522912</b>	_____	<b>6.88</b>	<b>6.88</b>
 549477	_____	6.88	6.88



### Grade 5 English (3rd Edition)

For Teachers



<b>532424</b>	_____	<b>89.17</b>	<b>80.25</b>
<b>532457</b>	_____	<b>14.17</b>	<b>12.75</b>

For Students

<b>532432</b>	_____	<b>36.11</b>	<b>32.50</b>
 546903	_____	38.06	34.25
 546119	_____	36.11	32.50
<b>532440</b>	_____	<b>6.88</b>	<b>6.88</b>
 549485	_____	6.88	6.88



### Grade 6 English (2nd Edition)

For Teachers



<b>200535</b>	_____	<b>89.17</b>	<b>80.25</b>
<b>200501</b>	_____	<b>14.17</b>	<b>12.75</b>

For Students

<b>281576</b>	_____	<b>36.11</b>	<b>32.50</b>
 546911	_____	38.06	34.25
 546127	_____	36.11	32.50
<b>200519</b>	_____	<b>6.88</b>	<b>6.88</b>
 549493	_____	6.88	6.88



### Grade 7 Writing & Grammar (4th Edition)

For Teachers



<b>518506</b>	_____	<b>93.33</b>	<b>84.00</b>
<b>518530</b>	_____	<b>15.28</b>	<b>13.75</b>

For Students

















<b>518514</b>	_____	<b>39.72</b>	<b>35.75</b>
 547331	_____	41.67	37.50
 546549	_____	39.72	35.75
<b>518522</b>	_____	<b>7.39</b>	<b>7.39</b>
 549501	_____	7.39	7.39





# Textbooks Order Form

Name \_\_\_\_\_









Account No. \_\_\_\_\_

When faxing or mailing your order, be sure to include page 98.

Item #	Qty.	List Price	Wholesale Price
<b>Grade 8 Writing &amp; Grammar (4th Edition)</b>			
For Teachers			
 523100	Teacher Edition (2 vols.)	93.33	84.00
523126	Assessments Answer Key	15.28	13.75
For Students			
523092	Student Worktext	39.72	35.75
 547349	eWorktext & Printed Student Worktext	41.67	37.50
 546556	eWorktext	39.72	35.75
523118	Assessments (assessments only; for 1 student)		7.39
 549519	eAssessments		7.39
<b>Grade 9 Writing &amp; Grammar (4th Edition)</b>			
For Teachers			
 527432	Teacher Edition (2 vols.)	93.33	84.00
527457	Assessments Answer Key	15.28	13.75
For Students			
527424	Student Worktext	39.72	35.75
 547356	eWorktext & Printed Student Worktext	41.67	37.50
 546564	eWorktext	39.72	35.75
527440	Assessments (assessments only; for 1 student)		7.39
 549527	eAssessments		7.39
<b>Grade 10 Writing &amp; Grammar (5th Edition) <span style="background-color: #90EE90;">NEW!</span></b>			
For Teachers			
 535500	Teacher Edition (2 vols.)	93.33	84.00
535534	Assessments Answer Key	15.28	13.75
For Students			
535518	Student Worktext	39.72	35.75
 547364	eWorktext & Printed Student Worktext	41.67	37.50
 546572	eWorktext	39.72	35.75
535526	Assessments (assessments only; for 1 student)		7.39
 549535	eAssessments		7.39
125351	<i>The Writer's Toolbox</i> (Grades 9–12)	47.78	43.00
<b>Grade 11 Writing &amp; Grammar (3rd Edition)</b>			
For Teachers			
 272229	Teacher Edition	93.33	84.00
272245	Assessments Answer Key	15.28	13.75
For Students			
514067	Student Worktext	39.72	35.75
 547372	eWorktext & Printed Student Worktext	41.67	37.50
 546580	eWorktext	39.72	35.75
272237	Assessments (assessments only; for 1 student)		7.39
 549543	eAssessments		7.39
125351	<i>The Writer's Toolbox</i> (Grades 9–12)	47.78	43.00

Item #	Qty.	List Price	Wholesale Price
<b>Grade 12 Writing &amp; Grammar (3rd Edition)</b>			
For Teachers			
 283614	Teacher Edition	93.33	84.00
283630	Assessments Answer Key	15.28	13.75
For Students			
522409	Student Worktext	39.72	35.75
 547380	eWorktext & Printed Student Worktext	41.67	37.50
 546598	eWorktext	39.72	35.75
283622	Assessments (assessments only; for 1 student)		7.39
 549550	eAssessments		7.39
125351	<i>The Writer's Toolbox</i> (Grades 9–12)	47.78	43.00
<b>Writing &amp; Grammar Resources</b>			
087247	<i>Someday You'll Write</i> , Yates (Grades 3–12)	8.99	8.09

## Spelling

<b>Grade 1 Spelling (4th Edition) <span style="background-color: #90EE90;">NEW LOOK!</span></b>			
For Teachers			
 539171	Teacher Edition	36.11	32.50
For Students			
539163	Student Worktext	32.50	29.25
 547208	eWorktext & Printed Student Worktext	34.17	30.75
 546416	eWorktext	32.50	29.25
525626	Newsprint Writing Paper (ream; Grades 2–3)	10.50	
<b>Grade 2 Spelling (2nd Edition)</b>			
For Teachers			
 275446	Teacher Edition	81.11	73.00
For Students			
514083	Student Worktext	32.50	29.25
 547216	eWorktext & Printed Student Worktext	34.17	30.75
 546424	eWorktext	32.50	29.25
<b>Grade 3 Spelling (2nd Edition)</b>			
For Teachers			
 277152	Teacher Edition	81.11	73.00
For Students			
514091	Student Worktext	32.50	29.25
 547224	eWorktext & Printed Student Worktext	34.17	30.75
 546432	eWorktext	32.50	29.25
<b>Grade 4 Spelling (2nd Edition)</b>			
For Teachers			
 279901	Teacher Edition	81.11	73.00







Name \_\_\_\_\_

Account No. \_\_\_\_\_

When faxing or mailing your order, be sure to include page 98.





# Textbooks Order Form

Item #	Qty.	List Price	Wholesale Price
<b>For Students</b>			
<b>517037</b>		<b>32.50</b>	<b>29.25</b>
 547232		34.17	30.75
 546440		32.50	29.25
<b>Grade 5 Spelling (2nd Edition)</b>			
<b>For Teachers</b>			
 <b>280164</b>		<b>81.11</b>	<b>73.00</b>
<b>For Students</b>			
<b>517045</b>		<b>32.50</b>	<b>29.25</b>
 547240		34.17	30.75
 546457		32.50	29.25

## Reading/Literature











See Phonics & English 1 and Spelling 1 for a complete phonics package.

### Grade 1 Reading (5th Edition) NEW!







Item #	Qty.	List Price	Wholesale Price
<b>For Teachers</b>			
 <b>535740</b>		<b>94.72</b>	<b>85.25</b>
<b>535773</b>		<b>25.28</b>	<b>22.75</b>
<b>For Students</b>			
<b>535757</b>		<b>89.17</b>	<b>80.25</b>
 548487		93.61	84.25
 547877		46.94	42.25
<b>535765</b>		<b>25.28</b>	<b>22.75</b>
 547083		26.67	24.00
 546291		25.28	22.75
<b>545350</b>		<b>5.99</b>	

### Grade 2 Reading (3rd Edition)

Item #	Qty.	List Price	Wholesale Price
<b>For Teachers</b>			
 <b>514828</b>		<b>106.67</b>	<b>96.00</b>
<b>294264</b>		<b>43.33</b>	<b>39.00</b>
513564		14.44	13.00
228304		34.44	31.00
<b>For Students</b>			
<b>536839</b>		<b>24.72</b>	<b>22.25</b>
<b>536789</b>		<b>24.72</b>	<b>22.25</b>
<b>536771</b>		<b>24.72</b>	<b>22.25</b>

Item #	Qty.	List Price	Wholesale Price
<b>536847</b>		<b>24.72</b>	<b>22.25</b>
 548495		25.83	23.25
 547885		13.06	11.75
 548503		25.83	23.25
 547893		13.06	11.75
 548511		25.83	23.25
 547901		13.06	11.75
 548529		25.83	23.25
 547919		13.06	11.75
<b>294256</b>		<b>43.33</b>	<b>39.00</b>
 547091		45.56	41.00
 546309		43.33	39.00
228296		32.50	29.25
<b>057596</b>		<b>8.99</b>	<b>8.09</b>
<b>043182</b>		<b>8.99</b>	<b>8.09</b>

### Grade 3 Reading (3rd Edition)

Item #	Qty.	List Price	Wholesale Price
<b>For Teachers</b>			
 <b>514836</b>		<b>106.67</b>	<b>96.00</b>
<b>299206</b>		<b>43.33</b>	<b>39.00</b>
513580		14.44	13.00
228304		34.44	31.00
<b>For Students</b>			
<b>539270</b>		<b>50.00</b>	<b>45.00</b>
<b>539288</b>		<b>50.00</b>	<b>45.00</b>
 548537		52.50	47.25
 547927		26.39	23.75
 548545		52.50	47.25
 547935		26.39	23.75
<b>299198</b>		<b>43.33</b>	<b>39.00</b>
 547109		45.56	41.00
 546317		43.33	39.00
228296		32.50	29.25
<b>107797</b>		<b>8.99</b>	<b>8.09</b>
<b>021782</b>		<b>8.99</b>	<b>8.09</b>

### Grade 4 Reading (3rd Edition)

Item #	Qty.	List Price	Wholesale Price
<b>For Teachers</b>			
 <b>503805</b>		<b>106.67</b>	<b>96.00</b>
<b>503755</b>		<b>43.33</b>	<b>39.00</b>
<b>506543</b>		<b>14.17</b>	<b>12.75</b>
<b>For Students</b>			
<b>523613</b>		<b>75.56</b>	<b>68.00</b>





Name \_\_\_\_\_

Account No. \_\_\_\_\_



When faxing or mailing your order, be sure to include page 98.

# Textbooks Order Form

Item #	Qty.	List Price	Wholesale Price
 548024	_____	39.72	35.75
<b>295923</b>	_____	<b>7.39</b>	
 549154	_____	7.39	



## Grade 12 British Literature (3rd Edition)

Item #	Qty.	List Price	Wholesale Price
 510149	_____	<b>93.89</b>	<b>84.50</b>
<b>510164</b>	_____	<b>15.28</b>	<b>13.75</b>

Item #	Qty.	List Price	Wholesale Price
<b>507087</b>	_____	<b>75.56</b>	<b>68.00</b>
 548644	_____	79.44	71.50
 548032	_____	39.72	35.75
<b>510156</b>	_____	<b>7.39</b>	
 549162	_____	7.39	

Item #	Qty.	List Price	Wholesale Price
205930	_____	14.95	

## BJ BookLinks

088377	_____	6.99	6.29
<b>233999</b>	_____	<b>27.78</b>	<b>25.00</b>
239038	_____	8.99	8.09
<b>231654</b>	_____	<b>27.78</b>	<b>25.00</b>
229203	_____	8.99	8.09
<b>244673</b>	_____	<b>27.78</b>	<b>25.00</b>
 043182	_____	8.99	8.09
<b>118240</b>	_____	<b>27.78</b>	<b>25.00</b>
 057596	_____	8.99	8.09
<b>118257</b>	_____	<b>27.78</b>	<b>25.00</b>
021782	_____	8.99	8.09
<b>120634</b>	_____	<b>27.78</b>	<b>25.00</b>
 107797	_____	8.99	8.09
<b>121004</b>	_____	<b>27.78</b>	<b>25.00</b>

## Handwriting

Item #	Qty.	List Price	Wholesale Price
 540427	_____	55.28	49.75
211722	_____	32.50	29.25
540419	_____	34.44	31.00

Item #	Qty.	List Price	Wholesale Price
<b>115188</b>	_____	<b>55.28</b>	<b>49.75</b>
010041	_____	30.00	27.00
211722	_____	32.50	29.25

Item #	Qty.	List Price	Wholesale Price
<b>268573</b>	_____	<b>27.78</b>	<b>25.00</b>
525626	_____	10.50	

Item #	Qty.	List Price	Wholesale Price
<b>117960</b>	_____	<b>55.28</b>	<b>49.75</b>
010041	_____	30.00	27.00

Item #	Qty.	List Price	Wholesale Price
<b>268581</b>	_____	<b>27.78</b>	<b>25.00</b>
525626	_____	10.50	
525634	_____	10.75	

Item #	Qty.	List Price	Wholesale Price
<b>122382</b>	_____	<b>55.28</b>	<b>49.75</b>
010041	_____	30.00	27.00

Item #	Qty.	List Price	Wholesale Price
<b>268599</b>	_____	<b>27.78</b>	<b>25.00</b>
525634	_____	10.75	

Item #	Qty.	List Price	Wholesale Price
<b>122416</b>	_____	<b>55.28</b>	<b>49.75</b>
010041	_____	30.00	27.00

Item #	Qty.	List Price	Wholesale Price
<b>271411</b>	_____	<b>27.78</b>	<b>25.00</b>
525634	_____	10.75	

Item #	Qty.	List Price	Wholesale Price
<b>122424</b>	_____	<b>55.28</b>	<b>49.75</b>
010041	_____	30.00	27.00

Item #	Qty.	List Price	Wholesale Price
<b>271429</b>	_____	<b>27.78</b>	<b>25.00</b>
029314	_____	2.26	
525634	_____	10.75	

## Vocabulary

Item #	Qty.	List Price	Wholesale Price
<b>249482</b>	_____	<b>30.00</b>	<b>27.00</b>
<b>249474</b>	_____	<b>27.78</b>	<b>25.00</b>

# Textbooks Order Form

Name \_\_\_\_\_

Account No. \_\_\_\_\_

When faxing or mailing your order, be sure to include page 98.

Item #	Qty.	List Price	Wholesale Price
<b>Grade 8 Vocabulary: Level B (3rd Edition)</b>			
For Teachers			
249508	_____	30.00	27.00
Teacher Edition			
For Students			
249490	_____	27.78	25.00
Student Worktext			
<b>Grade 9 Vocabulary: Level C (3rd Edition)</b>			
For Teachers			
249524	_____	30.00	27.00
Teacher Edition			
For Students			
249516	_____	27.78	25.00
Student Worktext			
<b>Grade 10 Vocabulary: Level D (3rd Edition)</b>			
For Teachers			
257790	_____	30.00	27.00
Teacher Edition			
For Students			
257808	_____	27.78	25.00
Student Worktext			
<b>Grade 11 Vocabulary: Level E (3rd Edition)</b>			
For Teachers			
257824	_____	30.00	27.00
Teacher Edition			
For Students			
257816	_____	27.78	25.00
Student Worktext			
<b>Grade 12 Vocabulary: Level F (3rd Edition)</b>			
For Teachers			
257840	_____	30.00	27.00
Teacher Edition			
For Students			
257832	_____	27.78	25.00
Student Worktext			

## Vacation Stations

### K5 Vacation Stations

For Students	233445	_____	Beyond the Back Door	15.00
--------------	--------	-------	----------------------	-------

### Grade 1 Vacation Stations

For Students	506345	_____	Wheels Westward	15.00
--------------	--------	-------	-----------------	-------

### Grade 2 Vacation Stations

For Students	503581	_____	Ocean Expedition	15.00
--------------	--------	-------	------------------	-------

### Grade 3 Vacation Stations

For Students	506352	_____	Jungle Journey	15.00
--------------	--------	-------	----------------	-------

### Grade 4 Vacation Stations

For Students	508754	_____	Polar Explorer	15.00
--------------	--------	-------	----------------	-------

### Grade 5 Vacation Stations

For Students	508762	_____	Outback Odyssey	15.00
--------------	--------	-------	-----------------	-------

### Grade 6 Vacation Stations

For Students	506360	_____	Egyptian Excursion	15.00
--------------	--------	-------	--------------------	-------

## Elementary Spanish

### Pasaporte al español Kit A (Grades 1–3)

For Teachers	228320	_____	Pasaporte al español Kit A (Grades 1–3)	559.17	503.25
For Students					
512178	_____	Worktext Step 1 (Grades 1–3)	34.44	31.00	
503573	_____	Worktext Step 2 (Grades 1–3)	34.44	31.00	
506485	_____	Worktext Step 3 (Grades 1–3)	34.44	31.00	

### Pasaporte al español Kit B (Grades 4–6)

For Teachers	233767	_____	Pasaporte al español Kit B (Grades 4–6)	559.17	503.25
For Students					
514026	_____	Worktext Step 4 (Grades 4–6)	34.44	31.00	
515403	_____	Worktext Step 5 (Grades 4–6)	34.44	31.00	
514034	_____	Worktext Step 6 (Grades 4–6)	34.44	31.00	

## Modern Languages

### Spanish 1 (3rd Edition)

For Teachers	500751	_____	Teacher Edition	84.44	76.00
	500744	_____	Activities Answer Key (Grades 9–12)	39.72	35.75
	500777	_____	Assessments Answer Key (Grades 9–12)	15.28	13.75

For Students

500231	_____	Student Edition (Grades 9–12)	68.61	61.75
548776	_____	eStudent Edition & Printed Student Edition	71.94	64.75
548164	_____	eStudent Edition	36.11	32.50
500736	_____	Activities (Grades 9–12)	36.11	32.50
547554	_____	eActivities & Printed Student Activity	38.06	34.25
546762	_____	eActivities	36.11	32.50
500769	_____	Assessments (assessments only; for 1 student; Grades 9–12)	7.39	
549303	_____	eAssessments	7.39	

### Spanish 2 (3rd Edition)

For Teachers	517722	_____	Teacher Edition	84.44	76.00
	517755	_____	Activities Answer Key	39.72	35.75
	517771	_____	Assessments Answer Key	15.28	13.75

For Students

517730	_____	Student Edition	68.61	61.75
548784	_____	eStudent Edition & Printed Student Edition	71.94	64.75
548172	_____	eStudent Edition	36.11	32.50
517748	_____	Activities	36.11	32.50
547562	_____	eActivities & Printed Student Activity	38.06	34.25
546770	_____	eActivities	36.11	32.50
517763	_____	Assessments (assessments only; for 1 student)	7.39	
549311	_____	eAssessments	7.39	







Name \_\_\_\_\_

Account No. \_\_\_\_\_

When faxing or mailing your order, be sure to include page 98.

# Textbooks

## Order Form

Item #	Qty.	List Price	Wholesale Price
<b>Spanish 3</b>			
For Teachers			
 <b>180307</b>		<b>84.44</b>	<b>76.00</b>
<b>182931</b>		<b>39.72</b>	<b>35.75</b>
<b>184184</b>		<b>15.28</b>	<b>13.75</b>
For Students			
<b>281642</b>		<b>68.61</b>	<b>61.75</b>
 548792		71.94	64.75
 548180		36.11	32.50
<b>182923</b>		<b>36.11</b>	<b>32.50</b>
 547570		38.06	34.25
 546788		36.11	32.50
<b>184192</b>			<b>7.39</b>
 549329			7.39

**Spanish Resources**

092684	Santa Biblia (Reina-Valera, 1960; Broadman and Holman; Grades 9–12)	11.00	
533067	Spanish/English Dictionary (Merriam-Webster)	7.50	

**Elementary Resources****Bible**

## Support Materials













125872	K5 Days of Creation Visual Packet	46.39	41.75
--------	-----------------------------------	-------	-------

**Heritage Studies**

## Support Materials

044180	Classroom Atlas (Rand McNally; Grades 1–6)	15.00	
--------	--	-------	--

**Historical Fiction and Biographies**

 031492	Brave the Wild Trail, Howard (1870s)	8.99	8.09
 034405	Captive Treasure, Howard (Grades 2–4)	8.99	8.09
 044404	Carolina's Courage, Yates (Grades 2–4)	8.99	8.09
 128025	Daniel Colton Kidnapped (1840s)	8.99	8.09
 128017	Daniel Colton Under Fire (1840s)	8.99	8.09
200261	Escape to Liechtenstein, Dunlop	8.99	8.09
 031229	A Father's Promise, Hess (Grades 4–7)	8.99	8.09
257261	Forbidden Gates, Williamson	8.99	8.09
200329	The Incredible Rescues, Dunlop	8.99	8.09
 072108	Mountain Born, Yates (Grades 4–7)	8.99	8.09
 078220	The Next Fine Day, Yates (Grades 4–7)	8.99	8.09
037358	On Yonder Mountain, Howard 1870s (Grades 2–4)	8.99	8.09
 102731	Pelts and Promises, Lohr (Grades 2–4)	8.99	8.09
 079830	A Place for Peter, Yates (Grades 4–7)	8.99	8.09
 057596	Pulling Together, Watkins (Grades 1–2)	8.99	8.09
262444	The Railway Children, Nesbit (Grades 4–7)	8.99	8.09
257485	River of Danger, Williamson (Grades 4–7)	8.99	8.09
 080564	Sarah Whitcher's Story, Yates (Grades 2–4)	8.99	8.09
200220	The Search for the Silver Eagle, Dunlop (Grades 4–7)	8.99	8.09
042887	The Secret of the Golden Cowrie, Repp (Grades 4–7)	8.99	8.09

 = Accelerated Reader

Item #	Qty.	List Price	Wholesale Price
257253	Silent Road to Rescue, Williamson (Grades 4–7)	8.99	8.09
 117382	Songbird, Lohr (Grades 4–7)	8.99	8.09
 128009	Suzannah and the Secret Coins, Schulte (Grades 4–7)	8.99	8.09
 127993	Suzannah Strikes Gold, Schulte (Grades 4–7)	8.99	8.09
021782	These Are My People, Howard (Grades 2–4)	8.99	8.09
106484	Trouble at Silver Pines Inn, Repp (Grades 3–4)	8.99	8.09
257998	Where I Belong, Kenney (Grades 4–7)	8.99	8.09

**Math**

## Resource Materials

204610	Backyard Math with Zac DVD Set (2 DVDs; 180 min.; Grade 1)	19.95	
--------	--	-------	--

**Language Skills**

## Support Materials

010041	Cursive Wall Charts (Grades 2–6)	30.00	27.00
109363	The Starting Line (12 storybooks; Grades K5–1)	20.00	18.00
087221	Take-Along Stories 1 (16 storybooks; Grades 1–2)	20.00	18.00
182196	Take-Along Stories 2 (10 storybooks; Grades 1–2)	20.00	18.00
109223	Up the Ladder (10 supplemental readers)	14.00	12.60

## Resource Materials

525626	Newsprint Writing Paper (ream; Grades 3–6)	10.50	
525634	White Writing Paper (ream; Grades 3–6)	10.75	

**Art**

## Support Materials

029314	Calligraphy Pen (Sanford)	2.26	
121749	With Art in Mind, Groebner (BJU Press; Grades 3–8)	31.94	28.75

**Spanish**

## Support Materials

076398	El Pato Paco, Turner and Kitching (Grades 1–5)	6.99	6.29
180281	Rosa la Osa, Turner and Kitching (Grades 1–5)	6.99	6.29
115022	¡Buenos Días, Carlitos!, Holmes (Grades 1–5)	6.99	6.29
180455	¡Buenas Tardes, Carlitos!, Holmes (Grades 1–5)	6.99	6.29

**Middle & High School Resources**

223339	Study Skills for Teens DVD (Grades 7–12)	22.95	
--------	--	-------	--

**Art**

121749	With Art in Mind, Groebner (BJU Press; Grades 3–8)	31.94	28.75
--------	--	-------	-------

**Bible**

## Resource Materials

127688	God's Prophetic Blueprint, Shelton (Grades 9–12)	12.00	
183418	Not by Chance, Talbert (Grades 11–12)	21.00	
181099	Stones of Witness, Custer (Grades 9–12)	55.00	

Essential items are in **Bold** = BJU Press Trove

# Textbooks Order Form

Name \_\_\_\_\_

Account No. \_\_\_\_\_

When faxing or mailing your order, be sure to include page 98.

Item #	Qty.	List Price	Wholesale Price	Item #	Qty.	List Price	Wholesale Price
<b>Heritage Studies</b>							
<b>Support Materials</b>							
001768	_____	American History in Verse, Stevenson (Grades 7–12)	11.00	033076	_____	Specimen Replacements for Dissection Kit	20.25
192401	_____	Children of the Storm: The Autobiography of Natasha Vins	8.99	205773	_____	Biology Dissection Labs DVD (72 min.; ShowForth; Grades 7, 10)	49.95
056861	_____	Faith of Our Fathers: Scenes from American Church History, Sidwell (Grades 7–12)	13.00	276576	_____	Biology Dissection Kit (Grades 7, 10)	80.25
046441	_____	Faith of Our Fathers: Scenes from Church History, Sidwell (Grades 7–12)	12.00	276584	_____	Biology Specimen Replacements for Dissection Kit (Grades 7, 10)	28.50
044172	_____	Historical Atlas of the World (softbound; Rand McNally; Grades 1–6)	17.25	<b>General Materials</b>			
<b>Historical Fiction</b>				188391	_____	The Stars Speak: Astronomy in the Bible, Custer (Grades 7–12)	19.50
237222	_____	The Choctaw Code, Ashabraner (Grades 7–12)	8.99	<b>General Resources</b>			
225656	_____	Ellenor's Exchange, Hayner (Grades 7–12)	8.99	<b>Administrative Resources</b>			
<b>AR</b> 063701	_____	False Coin, True Coin, Dick (Grades 7–12)	8.99	<b>Philosophy Resources</b>			
244012	_____	Gunner's Run, Barry (Grades 7–12)	8.99	506501	_____	Handbook of Christian Education	12.00
<b>AR</b> 031062	_____	The Hawk That Dare Not Hunt by Day, O'Dell (Grades 7–12)	8.99	<b>Books</b>			
<b>AR</b> 048561	_____	Hue and Cry, Yates (Grades 7–12)	8.99	247932	_____	Management Principles for Christian Schools; Deuink, Carruthers	26.50
<b>AR</b> 055673	_____	In Search of Honor, Hess (Grades 7–12)	8.99	<b>DVDs</b>			
<b>AR</b> 047787	_____	The Journeyman, Yates (Grades 7–12)	8.99	<b>Feature Films</b>			
<b>AR</b> 070466	_____	Men of Iron, Pyle (Grades 7–12)	8.99	205906	_____	Wine of Morning (DVD; 120 min.)	7.99
254987	_____	Out of Darkness, Petersen (Grades 7–12)	8.99	205963	_____	Flame in the Wind (DVD; 120 min.; closed-captioned)	7.99
<b>AR</b> 227454	_____	Regina Silsby's Phantom Militia, Brodeur (Grades 7–12)	8.99	206177	_____	Red Runs the River (DVD; 90 min.)	7.99
<b>AR</b> 208116	_____	Regina Silsby's Secret War, Brodeur (Grades 7–12)	8.99	525675	_____	Sheffey (DVD & Blu-ray; 135 min.)	19.95
204875	_____	A Sparrow Alone, Petersen (Grades 7–12)	8.99	205831	_____	Beyond the Night (DVD; 63 min.)	7.99
258004	_____	What About Cimmaron?, Snelling (Grades 7–12)	8.99	205864	_____	The Printing (DVD; 137 min.)	7.99
<b>AR</b> 190223	_____	Zoli's Legacy, Watkins (Grades 7–12)	8.99	206052	_____	The Treasure Map (DVD; 87 min.; closed-captioned; Grades 3–8)	7.99
<b>Language Skills</b>				206029	_____	Project Dinosaur (DVD; 64 min.; closed-captioned; Grades 3–8)	7.99
<b>Support Materials</b>				216358	_____	Appalachian Trial (DVD; 83 min.)	7.99
205930	_____	Romeo and Juliet (54 min. DVD)	14.95	276923	_____	Milltown Pride (DVD; 135 min.)	7.99
<b>Science</b>				<b>Math</b>			
<b>Dissection Materials</b>				204610	_____	Backyard Math with Zac DVD Set (2 DVDs; 180 min.; Grade 1)	19.95
034264	_____	Dissection Kit	78.75	<b>Science</b>			
				205773	_____	Biology Dissection Labs DVD (72 min.; ShowForth; Grades 7, 10)	49.95

Name \_\_\_\_\_

Account No. \_\_\_\_\_

When faxing or mailing your order, be sure to include page 98.

# Textbooks Order Form

Item #	Qty.	List Price	Wholesale Price
<b>Previous Editions</b>			
The following materials are available while supplies last.			
<b>Grade 1 Phonics &amp; English (4th Edition)</b>			
 507103	_____ Student Worktext	43.33	39.00
 507111	_____ Activities	36.11	32.50
<b>Grade 1 Reading (4th Edition)</b>			
 526491	_____ Student Readers Set (6 vols.)	89.17	80.25
 275206	_____ Student Worktext	25.28	22.75
<b>Grade 1 Math (4th Edition)</b>			
 527069	_____ Student Worktext	39.72	35.75
 294769	_____ Assessments (assessments only; for 1 student)		6.88
 294751	_____ Math 1 Reviews	15.00	13.50
<b>Grade 1 Spelling (3rd Edition)</b>			
 522466	_____ Student Worktext	32.50	29.25
<b>Grade 1 Handwriting (3rd Edition)</b>			
 296772	_____ Student Worktext	34.44	31.00
<b>Grade 4 Heritage Studies (3rd Edition)</b>			
 527044	_____ Student Edition	52.22	47.00
 295832	_____ Activities	36.39	32.75
 295840	_____ Assessments (assessments only; for 1 student)		6.88
<b>Grade 9 Algebra 1 (3rd Edition)</b>			
 516997	_____ Student Edition	71.94	64.75
 270611	_____ Activities	25.28	22.75
 270579	_____ Assessments (assessments only; for 1 student)		7.39
<b>Grade 10 Biology (5th Edition)</b>			
 515999	_____ Student Edition	86.11	77.50
 502070	_____ Student Lab Manual	38.33	34.50
 502120	_____ Assessments (assessments only; for 1 student)		7.39
<b>Grade 10 Writing &amp; Grammar (4th Edition)</b>			
 522458	_____ Student Worktext	39.72	35.75
 296574	_____ Assessments (assessments only; for 1 student)		7.39

# Christian Classroom Online Order Form

Name \_\_\_\_\_

Account No. \_\_\_\_\_

When faxing or mailing your order, be sure to include page 98.

## Christian Classroom Online **Option 1** Streaming Video Classroom License

Provides one facilitator login with access to the video content of all online courses. An unlimited number of students may simultaneously view a class. Does not provide access to eTextbooks or online assessment materials for students. **Required student materials may be purchased using the order form on pages 121–27.**

372839 Streaming Video License 169.00

### Course Title

1. \_\_\_\_\_
2. \_\_\_\_\_
3. \_\_\_\_\_
4. \_\_\_\_\_
5. \_\_\_\_\_
6. \_\_\_\_\_
7. \_\_\_\_\_
8. \_\_\_\_\_

372839 Streaming Video License 169.00

### Course Title

1. \_\_\_\_\_
2. \_\_\_\_\_
3. \_\_\_\_\_
4. \_\_\_\_\_
5. \_\_\_\_\_
6. \_\_\_\_\_
7. \_\_\_\_\_
8. \_\_\_\_\_

372839 Streaming Video License 169.00

### Course Title

1. \_\_\_\_\_
2. \_\_\_\_\_
3. \_\_\_\_\_
4. \_\_\_\_\_
5. \_\_\_\_\_
6. \_\_\_\_\_
7. \_\_\_\_\_
8. \_\_\_\_\_

372839 Streaming Video License 169.00

### Course Title

1. \_\_\_\_\_
2. \_\_\_\_\_
3. \_\_\_\_\_
4. \_\_\_\_\_
5. \_\_\_\_\_
6. \_\_\_\_\_
7. \_\_\_\_\_
8. \_\_\_\_\_

Teacher editions and eTextbooks for Christian Classroom Online are available upon request. Please contact your Precept sales representative or call Customer Service at 800.845.5731.



Name \_\_\_\_\_

Account No. \_\_\_\_\_

When faxing or mailing your order, be sure to include page 98.

# Christian Classroom Online Order Form

## Christian Classroom Online **Option 2** Online Course Enrollment

Provides access for one student to the video content of the specified course(s) and, where applicable, to eTextbooks and online assessments for the course(s). Full grade with books includes student materials only. Order facilitation materials separately. No substitutions. **Required student materials may be purchased using the order form on pages 121–27.**

Student eTextbook included with this subject

Online assessments included with this subject

Item #	Qty.	Description	Wholesale Price	Item #	Qty.	Description	Wholesale Price
<b>K4–K5</b>				<b>Grade 3</b>			
455584	___	<b>NEW!</b> K4 Full Grade Online Course Enrollment	229.00	<input type="checkbox"/> 459271	___	<b>NEW!</b> Grade 3 Heritage Studies Online Course Enrollment	89.00
455592	___	<b>NEW!</b> K4 Full Grade Online Course Enrollment w/ Books	229.00	404475	___	Grade 3 Math Online Course Enrollment	89.00
412767	___	K5 Full Grade Online Course Enrollment	339.00	446492	___	Grade 3 English Online Course Enrollment	89.00
447300	___	K5 Full Grade Online Course Enrollment w/Books	449.00	419549	___	Grade 3 Spelling Online Course Enrollment	89.00
414169	___	Grade K5 Bible Online Course Enrollment	119.00	<input type="checkbox"/> 413484	___	Grade 3 Reading Online Course Enrollment	89.00
412882	___	Grade K5 Focus on Fives Online Course Enrollment	119.00	404467	___	Grade 3 Handwriting Online Course Enrollment	89.00
431049	___	Grade K5 Math Online Course Enrollment	119.00	<b>Grade 4</b>			
<b>Grade 1</b>				457135	___	<b>NEW!</b> Grade 4 Full Grade Online Course Enrollment	459.00
446401	___	Grade 1 Full Grade Online Course Enrollment	459.00	457150	___	<b>NEW!</b> Grade 4 Full Grade Online Course Enrollment w/Books	789.00
447318	___	Grade 1 Full Grade Online Course Enrollment w/ Books	789.00	444760	___	Grade 4 Bible Online Course Enrollment	89.00
404277	___	Grade 1 Bible Truths Online Course Enrollment	89.00	<input type="checkbox"/> 394080	___	Grade 4 Science Online Course Enrollment	89.00
<input type="checkbox"/> 446476	___	Grade 1 Science Online Course Enrollment	89.00	<input type="checkbox"/> 394072	___	Grade 4 Heritage Studies Online Course Enrollment	89.00
<input type="checkbox"/> 446484	___	Grade 1 Heritage Studies Online Course Enrollment	89.00	446500	___	Grade 4 Math Online Course Enrollment	89.00
404301	___	Grade 1 Math Online Course Enrollment	89.00	457143	___	<b>NEW!</b> Grade 4 English Online Course Enrollment	89.00
404285	___	Grade 1 Phonics/Reading/Handwriting Online Course Enrollment	89.00	394098	___	Grade 4 Spelling Online Course Enrollment	89.00
444745	___	Grade 1 Spelling Online Course Enrollment	89.00	<input type="checkbox"/> 444778	___	Grade 4 Reading Online Course Enrollment	89.00
<b>Grade 2</b>				404558	___	Grade 4 Handwriting Online Course Enrollment	89.00
453787	___	Grade 2 Full Grade Online Course Enrollment	459.00	<b>Grade 5</b>			
453837	___	Grade 2 Full Grade Online Course Enrollment w/ Books	789.00	453589	___	Grade 5 Full Grade Online Course Enrollment	569.00
404343	___	Grade 2 Bible Truths Online Course Enrollment	89.00	453563	___	Grade 5 Full Grade Online Course Enrollment w/ Books	789.00
<input type="checkbox"/> 453720	___	Grade 2 Science Online Course Enrollment	89.00	<input checked="" type="checkbox"/> 446518	___	Grade 5 Bible Online Course Enrollment	99.00
<input type="checkbox"/> 453738	___	Grade 2 Heritage Studies Online Course Enrollment	89.00	<input type="checkbox"/> <input checked="" type="checkbox"/> 394106	___	Grade 5 Science Online Course Enrollment	99.00
404384	___	Grade 2 Math Online Course Enrollment	89.00	<input type="checkbox"/> <input checked="" type="checkbox"/> 419556	___	Grade 5 Heritage Studies Online Course Enrollment	99.00
412601	___	Grade 2 English Online Course Enrollment	89.00	<input checked="" type="checkbox"/> 453571	___	Grade 5 Math Online Course Enrollment	99.00
420596	___	Grade 2 Spelling Online Course Enrollment	89.00	<input checked="" type="checkbox"/> 404624	___	Grade 5 English Online Course Enrollment	99.00
<input type="checkbox"/> 420430	___	Grade 2 Reading Online Course Enrollment	89.00	394114	___	Grade 5 Spelling Online Course Enrollment	99.00
404376	___	Grade 2 Handwriting Online Course Enrollment	89.00	<input type="checkbox"/> <input checked="" type="checkbox"/> 444794	___	Grade 5 Reading Online Course Enrollment	99.00
<b>Grade 3</b>				404640	___	Grade 5 Handwriting Online Course Enrollment	99.00
457473	___	<b>NEW!</b> Grade 3 Full Grade Online Course Enrollment	459.00	<b>Grade 6</b>			
457481	___	<b>NEW!</b> Grade 3 Full Grade Online Course Enrollment w/Books	789.00	453803	___	<b>NEW!</b> Grade 6 Full Grade Online Course Enrollment	569.00
404434	___	Grade 3 Bible Truths Online Course Enrollment	89.00	453845	___	<b>NEW!</b> Grade 6 Full Grade Online Course Enrollment w/Books	789.00
<input type="checkbox"/> 457606	___	<b>NEW!</b> Grade 3 Science Online Course Enrollment	89.00	<input checked="" type="checkbox"/> 393975	___	Grade 6 Bible Truths Online Course Enrollment	99.00
				<input type="checkbox"/> <input checked="" type="checkbox"/> 394031	___	Grade 6 Science Online Course Enrollment	99.00

Teacher editions and eTextbooks for Christian Classroom Online are available upon request. Please contact your Precept sales representative or call Customer Service at 800.845.5731.

# Christian Classroom Online Order Form

Name \_\_\_\_\_

Account No. \_\_\_\_\_

When faxing or mailing your order, be sure to include page 98.

Item #	Qty.	Description	Wholesale Price
<input type="checkbox"/> <input checked="" type="checkbox"/>		393991 _____ Grade 6 Heritage Studies Online Course Enrollment	99.00
<input type="checkbox"/> <input checked="" type="checkbox"/>		457283 _____ <b>NEW!</b> Grade 6 Math Online Course Enrollment	99.00
<input checked="" type="checkbox"/>		393983 _____ Grade 6 English Online Course Enrollment	99.00
		394049 _____ Grade 6 Spelling Online Course Enrollment	99.00
<input type="checkbox"/> <input checked="" type="checkbox"/>		453746 _____ <b>NEW!</b> Grade 6 Literature Online Course Enrollment	99.00
		394007 _____ Grade 6 Handwriting Online Course Enrollment	99.00

## Grade 7

		457739 _____ <b>NEW!</b> Grade 7 Full Grade Online Course Enrollment	569.00
		457754 _____ <b>NEW!</b> Grade 7 Full Grade Online Course Enrollment w/Books	789.00
<input checked="" type="checkbox"/>		446526 _____ Grade 7 Bible Online Course Enrollment	119.00
<input type="checkbox"/> <input checked="" type="checkbox"/>		457747 _____ <b>NEW!</b> Grade 7 Life Science Online Course Enrollment	119.00
<input type="checkbox"/> <input checked="" type="checkbox"/>		412809 _____ Grade 7 World Studies Online Course Enrollment	119.00
<input type="checkbox"/> <input checked="" type="checkbox"/>		412817 _____ Grade 7 Fundamentals of Math Online Course Enrollment	119.00
<input type="checkbox"/> <input checked="" type="checkbox"/>		446534 _____ Grade 7 English Online Course Enrollment	119.00

## Grade 8

		453811 _____ Grade 8 Full Grade Online Course Enrollment	569.00
		453852 _____ Grade 8 Full Grade Online Course Enrollment w/Books	789.00
<input checked="" type="checkbox"/>		453753 _____ Grade 8 Bible Online Course Enrollment	119.00
<input type="checkbox"/> <input checked="" type="checkbox"/>		429480 _____ Grade 8 Earth Science Online Course Enrollment	119.00
<input type="checkbox"/> <input checked="" type="checkbox"/>		419564 _____ Grade 8 American Republic Online Course Enrollment	119.00
<input type="checkbox"/> <input checked="" type="checkbox"/>		411678 _____ Grade 8 Pre-Algebra Online Course Enrollment	119.00
<input type="checkbox"/> <input checked="" type="checkbox"/>		453761 _____ Grade 8 English Online Course Enrollment	119.00

## Grade 9

		453480 _____ <b>NEW!</b> Grade 9 Full Grade Online Course Enrollment	569.00
		447367 _____ <b>NEW!</b> Grade 9 Full Grade Online Course Enrollment w/Books	789.00
<input checked="" type="checkbox"/>		404954 _____ Grade 9 Bible Online Course Enrollment	119.00
<input type="checkbox"/> <input checked="" type="checkbox"/>		444810 _____ Grade 9 Physical Science Online Course Enrollment	119.00
<input type="checkbox"/> <input checked="" type="checkbox"/>		446542 _____ <b>NEW!</b> Grade 9 Cultural Geography Online Course Enrollment	119.00
<input type="checkbox"/> <input checked="" type="checkbox"/>		458356 _____ <b>NEW!</b> Grade 9 Algebra 1 Online Course Enrollment	119.00
<input checked="" type="checkbox"/>		404970 _____ Grade 9 Writing & Grammar Online Course Enrollment	89.00
<input type="checkbox"/> <input checked="" type="checkbox"/>		404988 _____ Grade 9 Fundamentals of Literature Online Course Enrollment	89.00

## Grade 10

		458224 _____ <b>NEW!</b> Grade 10 Full Grade Online Course Enrollment	569.00
		458232 _____ <b>NEW!</b> Grade 10 Full Grade Online Course Enrollment w/Books	789.00
<input checked="" type="checkbox"/>		458216 _____ <b>NEW!</b> Grade 10 Bible Online Course Enrollment	119.00
<input type="checkbox"/> <input checked="" type="checkbox"/>		405092 _____ Grade 10 Biology Online Course Enrollment	119.00

Item #	Qty.	Description	Wholesale Price
<input type="checkbox"/> <input checked="" type="checkbox"/>		444836 _____ Grade 10 World History Online Course Enrollment	119.00
<input type="checkbox"/> <input checked="" type="checkbox"/>		419572 _____ Grade 10 Geometry Online Course Enrollment	119.00
<input checked="" type="checkbox"/>		394155 _____ Grade 10 Writing & Grammar Online Course Enrollment	89.00
<input type="checkbox"/> <input checked="" type="checkbox"/>		394163 _____ Grade 10 Elements of Literature Online Course Enrollment	89.00

## Grade 11

		446468 _____ Grade 11 Full Grade Online Course Enrollment	569.00
		447375 _____ Grade 11 Full Grade Online Course Enrollment w/Books	789.00
<input checked="" type="checkbox"/>		405118 _____ Grade 11 Bible Online Course Enrollment	119.00
<input type="checkbox"/> <input checked="" type="checkbox"/>		446559 _____ Grade 11 Chemistry Online Course Enrollment	119.00
<input type="checkbox"/> <input checked="" type="checkbox"/>		418392 _____ Grade 11 U.S. History Online Course Enrollment	119.00
<input type="checkbox"/> <input checked="" type="checkbox"/>		394171 _____ Grade 11 Algebra 2 Online Course Enrollment	119.00
<input type="checkbox"/> <input checked="" type="checkbox"/>		444851 _____ Grade 11 English Online Course Enrollment	119.00

## Grade 12

		458075 _____ <b>NEW!</b> Grade 12 Full Grade Online Course Enrollment	569.00
		458091 _____ <b>NEW!</b> Grade 12 Full Grade Online Course Enrollment w/Books	789.00
<input checked="" type="checkbox"/>		405191 _____ Grade 12 Bible Online Course Enrollment	119.00
<input type="checkbox"/> <input checked="" type="checkbox"/>		431932 _____ Grade 12 Physics Online Course Enrollment	119.00
<input type="checkbox"/> <input checked="" type="checkbox"/>		458083 _____ <b>NEW!</b> Grade 12 American Government Online Course Enrollment	89.00
<input type="checkbox"/> <input checked="" type="checkbox"/>		431577 _____ Grade 12 Economics Online Course Enrollment	89.00
<input type="checkbox"/> <input checked="" type="checkbox"/>		432963 _____ Grade 12 Precalculus Online Course Enrollment	119.00
<input checked="" type="checkbox"/>		405217 _____ Grade 12 Writing & Grammar Online Course Enrollment	89.00
<input type="checkbox"/> <input checked="" type="checkbox"/>		405225 _____ Grade 12 British Literature Online Course Enrollment	89.00

## Modern Language

<input type="checkbox"/> <input checked="" type="checkbox"/>		405282 _____ Spanish 1 Online Course Enrollment	119.00
		446302 _____ Spanish 1 Online Course Enrollment w/Books	129.00
<input type="checkbox"/> <input checked="" type="checkbox"/>		394189 _____ Spanish 2 Online Course Enrollment	119.00
		446310 _____ Spanish 2 Online Course Enrollment w/Books	129.00
<input type="checkbox"/> <input checked="" type="checkbox"/>		419622 _____ Spanish 3 Online Course Enrollment	119.00
		446328 _____ Spanish 3 Online Course Enrollment w/Books	129.00
		444992 _____ American Sign Language Online Course Enrollment (only available for Option 2)	119.00

## Electives

		446575 _____ Consumer Math Online Course Enrollment	119.00
		453795 _____ Consumer Math Online Course Enrollment w/Books	129.00

Consumer Math may be substituted for Precalculus in Grade 12.

**Option 3: Branded Online School Management** is similar to Option 2 but gives schools access to their own customized, branded site. This option is available by special offer only and additional costs and requirements apply. Talk to your Precept sales representative for more information.

Teacher editions and eTextbooks for Christian Classroom Online are available upon request. Please contact your Precept sales representative or call Customer Service at 800.845.5731.

Name \_\_\_\_\_

Account No. \_\_\_\_\_

When faxing or mailing your order, be sure to include page 98.

# Christian Classroom Online Order Form

## Textbooks & Printed Materials for Options 1 and 2



All subjects give facilitator access to needed course information and teacher-prepared handouts. Reproducible versions of facilitator and student packets included with CCO facilitator login. Printed copies included with DVDs.

An eTextbook is included with this subject in CCO, Option 2. Printed student text is optional. Special student text price at 35% discount offered to schools using Option 2.

K4–Grade 4: No tests/quizzes included with facilitator login. Test packs and answer keys recommended.

Grades 5–12: Reproducible tests/quizzes included with facilitator login and/or facilitator packets. Online tests/quizzes available with CCO, Option 2 only (see page 97).

Item #	Qty.	Description	Wholesale Price	Special Price
 523795	___	Visual Packet (3rd ed.)		
523803	___	Phonics Packet (3rd ed.)		
517508	___	Activity Packet	41.75	
517524	___	Writing Packet	34.50	
517516	___	Practice Cards	15.75	
455519	___	Student Handouts	5.00	
455527	___	Facilitator packet (Parent Guide)	10.00	

### K5

#### Bible Truths (2nd ed.)

 262717	___	Student Packet	31.00	
408658	___	Student Handouts	5.00	
433102	___	Facilitator Packet (Parent Guide)	10.00	

#### Focus on Fives (4th ed.)

 504985	___	Student Worktext	41.75	
504977	___	Reading Books for K5 (34 books)	60.25	
505057	___	Phonics Practice for K5	29.25	
504928	___	Phonics & Review Cards	12.75	
452300	___	Student Handouts	5.00	
428631	___	Facilitator Packet (Parent Guide)	10.00	

#### Math (3rd ed.)

 211201	___	Student Worktext	31.00	
211219	___	Student Manipulatives Packet	21.50	
058164	___	Unifix Cubes (100 pcs. with instructions; Didax Educational Resources; Grades K5–2)	14.00	
433961	___	Student Handouts	5.00	

Item #	Qty.	Description	Wholesale Price	Special Price
431072	___	Facilitator Packet (Parent Guide)	10.00	

### Grade 1

#### Bible (3rd ed.)

 265306	___	Student Worktext	31.00	
125955	___	Student Materials Packet	19.00	
125963	___	Assessments (assessments only; for 1 student)	6.88	
125971	___	Assessments Answer Key	12.75	
408682	___	Student Handouts	5.00	
433128	___	Facilitator Packet (Parent Guide)	10.00	

#### Science (4th ed.)

<input type="checkbox"/> 525550	___	Student Edition	51.00	33.15
 508838	___	Activities	34.50	
508846	___	Activities Answer Key	20.50	
508887	___	Assessments (assessments only; for 1 student)	6.88	
508895	___	Assessments Answer Key	12.75	
446831	___	Student Handouts	5.00	
446948	___	Facilitator Packet (Parent Guide)	10.00	

#### Heritage Studies (4th ed.)

<input type="checkbox"/> 530915	___	Student Edition	47.00	30.55
 517417	___	Activities	32.75	
517425	___	Activities Answer Key	20.50	
517458	___	Assessments (assessments only; for 1 student)	6.88	
517466	___	Assessments Answer Key	12.75	
446823	___	Student Handouts	5.00	
446930	___	Facilitator Packet (Parent Guide)	10.00	

#### Math (3rd ed.)

 216168	___	Student Worktext	35.75	
216234	___	Student Manipulatives Packet	21.50	
216242	___	Assessments (assessments only; for 1 student)	6.88	
216259	___	Assessments Answer Key	12.75	
408716	___	Student Handouts	5.00	
412262	___	Facilitator Packet (Parent Guide)	10.00	

#### Phonics & English, Reading and Handwriting (3rd ed.)

 281683	___	Phonics & English Student Worktext	39.00	
211821	___	Phonics Practice Book	32.50	
526483	___	Student Readers Set (6 vols.)	80.25	52.16
211383	___	Reading Student Worktext	22.75	
239038	___	<i>Buttercup Hill</i> , Berry (Grades 1–2)	8.09	
088377	___	<i>Once in Blueberry Dell</i> , Watkins (Grades K4–1)	6.29	
229203	___	<i>Looking for Home</i> , Berry (Grades 1–2)	8.09	

Teacher editions and eTextbooks for Christian Classroom Online are available upon request. Please contact your Precept sales representative or call Customer Service at 800.845.5731.

# Christian Classroom Online Order Form

Name \_\_\_\_\_

Account No. \_\_\_\_\_

When faxing or mailing your order, be sure to include page 98.

Item #	Qty.	Description	Wholesale Price	Special Price
296772	___	Student Worktext	31.00	
231654	___	BJ BookLinks: Buttercup Hill Set (guide & novel; Grades 1–2)	25.00	
233999	___	BJ BookLinks: Once in Blueberry Dell Set (guide & novel; Grades K4–1)	25.00	
244673	___	BJ BookLinks: Looking for Home Set (guide & novel; Grades 1–2)	25.00	
408690	___	Student Handouts	5.00	
412247	___	Facilitator Packet (Parent Guide)	10.00	

## Spelling (3rd ed.)



522466	___	Student Worktext	29.25	
452367	___	Student Handouts	5.00	
441683	___	Facilitator Packet (Parent Guide)	10.00	

## Grade 2

### Bible (3rd ed.)



113506	___	Student Worktext	31.00	
113589	___	Student Materials Packet	19.00	
113597	___	Assessments (assessments only; for 1 student)	6.88	
113605	___	Assessments Answer Key	12.75	
057885	___	<i>A Question of Yams</i> , Repp (Grades 1–2)	8.09	
102731	___	<i>Pelts and Promises</i> , Lohr (Grades 2–4)	8.09	
408740	___	Student Handouts	5.00	
412296	___	Facilitator Packet (Parent Guide)	10.00	

### Science (5th ed.)



530089	___	Student Edition	51.00	33.15
517680	___	Activities	34.50	
517698	___	Activities Answer Key	20.50	
517649	___	Assessments (assessments only; for 1 student)	6.88	
517656	___	Assessments Answer Key	12.75	
454231	___	Student Handouts	5.00	
454298	___	Facilitator Packet (Parent Guide)	10.00	

### Heritage Studies (4th ed.)

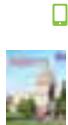

520775	___	Student Edition	47.00	30.55
520791	___	Activities	32.75	
520809	___	Activities Answer Key	20.50	
520817	___	Assessments (assessments only; for 1 student)	6.88	
520825	___	Assessments Answer Key	12.75	
454223	___	Student Handouts	5.00	
454280	___	Facilitator Packet (Parent Guide)	10.00	

### Math (3rd ed.)



281618	___	Student Worktext	35.75	
224402	___	Student Manipulatives Packet	21.50	
224410	___	Assessments (assessments only; for 1 student)	6.88	
224436	___	Assessments Answer Key	12.75	
408781	___	Student Handouts	5.00	
412338	___	Facilitator Packet (Parent Guide)	10.00	

Item #	Qty.	Description	Wholesale Price	Special Price
--------	------	-------------	-----------------	---------------

### English (3rd ed.)



501452	___	Student Worktext	32.50	
501692	___	Assessments (assessments only; for 1 student)	6.88	
501718	___	Assessments Answer Key	12.75	
434035	___	Student Handouts	5.00	
428623	___	Facilitator Packet (Parent Guide)	10.00	

### Spelling (2nd ed.)



514083	___	Student Worktext	29.25	
420570	___	Student Handouts	5.00	
420562	___	Facilitator Packet (Parent Guide)	10.00	

### Reading (3rd ed.)



536839	___	Student Edition 2A: All God's Creatures	22.25	14.46
536789	___	Student Edition 2B: Hearts and Hands	22.25	14.46
536771	___	Student Edition 2C: Memories to Keep	22.25	14.46
536847	___	Student Edition 2D: Precious Treasures	22.25	14.46



294256	___	Student Worktext	39.00	
294264	___	Worktext Answer Key	39.00	
043182	___	<i>The Treasure of Pelican Cove</i> , Howard (Grades 2–4)	8.09	

057596 \_\_\_ *Pulling Together*, Watkins (Grades 1–2) 8.09

118240 \_\_\_ BJ BookLinks: The Treasure of Pelican Cove Set (guide & novel; Grades 2–4) 25.00

118257 \_\_\_ BJ BookLinks: Pulling Together Set (guide & novel; Grades 2–4) 25.00

434076 \_\_\_ Student Handouts 5.00

412478 \_\_\_ Facilitator Packet (Parent Guide) 10.00

### Handwriting (2nd ed.)



268573	___	Student Worktext	25.00	
434050	___	Student Handouts	5.00	
433201	___	Facilitator Packet (Parent Guide)	10.00	

## Grade 3

### Bible (3rd ed.)



256156	___	Student Worktext	31.00	
114751	___	Student Materials Packet	19.00	
114769	___	Assessments (assessments only; for 1 student)	6.88	

114777 \_\_\_ Assessments Answer Key 12.75

113100 \_\_\_ *Escape*, Dunckel (Grades 1–3) 8.09

082685 \_\_\_ *Peanut Butter Friends in a Chop Suey World*, Brammer (Grades 4–7) 8.09

434100 \_\_\_ Student Handouts 5.00

412379 \_\_\_ Facilitator Packet (Parent Guide) 10.00

### Science (5th ed.) **NEW!**



522581 \_\_\_ Student Edition 51.00 33.15

522607 \_\_\_ Activities 34.50

522615 \_\_\_ Activities Answer Key 20.50

522623 \_\_\_ Assessments (assessments only; for 1 student) 6.88









Teacher editions and eTextbooks for Christian Classroom Online are available upon request. Please contact your Precept sales representative or call Customer Service at 800.845.5731.

Name \_\_\_\_\_

Account No. \_\_\_\_\_

When faxing or mailing your order, be sure to include page 98.

# Christian Classroom Online Order Form

Item #	Qty.	Description	Wholesale Price	Special Price
522631	___	Assessments Answer Key	12.75	
457531	___	Student Handouts	5.00	
457549	___	Facilitator Packet (Parent Guide)	10.00	
<b>Heritage Studies (4th ed.) <span style="background-color: green; color: white; padding: 2px;">NEW!</span></b>				
 526640	___	Student Edition	47.00	30.55
526665	___	Activities	32.75	
 526673	___	Activities Answer Key	20.50	
526681	___	Assessments (assessments only; for 1 student)	6.88	
526699	___	Assessments Answer Key	12.75	
457358	___	Student Handouts	5.00	
457366	___	Facilitator Packet (Parent Guide)	10.00	
<b>Math (3rd ed.)</b>				
296798	___	Student Worktext	35.75	
 231688	___	Student Manipulatives Packet	21.50	
231720	___	Assessments (assessments only; for 1 student)	6.88	
231746	___	Assessments Answer Key	12.75	
408864	___	Student Handouts	5.00	
412411	___	Facilitator Packet (Parent Guide)	10.00	
<b>English (3rd ed.)</b>				
 517573	___	Student Worktext	32.50	
517599	___	Assessments (assessments only; for 1 student)	6.88	
517607	___	Assessments Answer Key	12.75	
446849	___	Student Handouts	5.00	
446955	___	Facilitator Packet (Parent Guide)	10.00	
<b>Spelling (2nd ed.)</b>				
 514091	___	Student Worktext	29.25	
419259	___	Student Handouts	5.00	
419069	___	Facilitator Packet (Parent Guide)	10.00	
<b>Reading (3rd ed.)</b>				
 539270	___	Student Edition 3A: Adventures in Reading	45.00	29.25
 539288	___	Student Edition 3B: Adventures in Reading	45.00	29.25
299198	___	Student Worktext	39.00	
 299206	___	Worktext Answer Key	39.00	
107797	___	<i>The Case of the Dognapped Cat</i> , Howard (Grades 2–4)	8.09	
021782	___	<i>These Are My People</i> , Howard (Grades 2–4)	8.09	
121004	___	BJ BookLinks: The Case of the Dognapped Cat Set (guide & novel; Grades 2–4)	25.00	
120634	___	BJ BookLinks: These Are My People Set (guide & novel; Grades 2–4)	25.00	
452318	___	Student Handouts	5.00	
428672	___	Facilitator Packet (Parent Guide)	10.00	

## Handwriting (2nd ed.)



 268581	___	Student Worktext	25.00
434134	___	Student Handouts	5.00
412403	___	Facilitator Packet (Parent Guide)	10.00

## Grade 4



### Bible (1st ed.)

 512319	___	Student Worktext	31.00
512335	___	Assessments (assessments only; for 1 student)	6.88
512343	___	Assessments Answer Key	12.75
442384	___	Student Handouts	5.00
442376	___	Facilitator Packet (Parent Guide)	10.00

### Science (4th ed.)

 527051	___	Student Edition	51.00	33.15
296897	___	Activities	34.50	
 296939	___	Assessments (assessments only; for 1 student)	6.88	
296954	___	Assessments Answer Key	12.75	
434233	___	Student Handouts	5.00	
413377	___	Facilitator Packet (Parent Guide)	10.00	

### Heritage Studies (3rd ed.)

 527044	___	Student Edition	47.00	30.55
295832	___	Activities	32.75	
 295840	___	Assessments (assessments only; for 1 student)	6.88	
295865	___	Assessments Answer Key	12.75	
434191	___	Student Handouts	5.00	
413369	___	Facilitator Packet (Parent Guide)	10.00	

### Math (4th ed.)

 515536	___	Worktext	35.75
515544	___	Student Manipulatives Packet	21.50
515585	___	Activities	13.50
515569	___	Assessments (assessments only; for 1 student)	6.88
515619	___	Assessments Answer Key	12.75
446856	___	Student Handouts	5.00
446963	___	Facilitator Packet (Parent Guide)	10.00

### English (3rd ed.) NEW!

 522896	___	Student Worktext	32.50
522912	___	Assessments (assessments only; for 1 student)	6.88
522920	___	Assessments Answer Key	12.75
454249	___	Student Handouts	5.00
454306	___	Facilitator Packet (Parent Guide)	10.00

### Spelling (2nd ed.)

 517037	___	Student Worktext	29.25
434241	___	Student Handouts	5.00
413385	___	Facilitator Packet (Parent Guide)	10.00



Teacher editions and eTextbooks for Christian Classroom Online are available upon request. Please contact your Precept sales representative or call Customer Service at 800.845.5731.

# Christian Classroom Online Order Form

Name \_\_\_\_\_

Account No. \_\_\_\_\_



When faxing or mailing your order, be sure to include page 98.



Item #	Qty.	Description	Wholesale Price	Special Price
<b>Reading (3rd ed.)</b>				
 523613	___	Student Edition: Voyages	68.00	44.20
 503748	___	Student Worktext	39.00	
503755	___	Worktext Answer Key	39.00	
514224	___	<i>Sarah, Plain and Tall</i> , MacLachlan	7.99	
023523	___	<i>Medallion</i> , Watkins(Grades 4–7)	8.09	
514232	___	<i>The Lion, the Witch and the Wardrobe</i> , Lewis	8.99	
506535	___	Assessments (assessments only; for 1 student)	6.88	
506543	___	Assessments Answer Key	12.75	
441790	___	Student Handouts	5.00	
441782	___	Facilitator Packet (Parent Guide)	10.00	

<b>Handwriting (2nd ed.)</b>				
 268599	___	Student Worktext	25.00	
434209	___	Student Handouts	5.00	
412486	___	Facilitator Packet (Parent Guide)	10.00	

## Grade 5

<b>Bible (1st ed.)</b>				
 515288	___	Student Worktext	31.00	
446864	___	Student Handouts	5.00	
446971	___	Facilitator Packet (Parent Guide)	10.00	

<b>Science (4th ed.)</b>				
 522425	___	Student Edition	51.00	33.15
 293019	___	Activities	34.50	
434316	___	Student Handouts	5.00	
413393	___	Facilitator Packet (Parent Guide)	10.00	

<b>Heritage Studies (4th ed.)</b>				
 536078	___	Student Edition	47.00	30.55
 500371	___	Activities	32.75	
507400	___	Activities Answer Key	20.50	
419267	___	Student Handouts	5.00	
419077	___	Facilitator Packet (Parent Guide)	10.00	

<b>Math (4th ed.)</b>				
 518894	___	Student Worktext	35.75	
453514	___	Student Handouts	5.00	
453522	___	Facilitator Packet (Parent Guide)	10.00	

<b>English (2nd ed.)</b>				
 273722	___	Student Worktext	32.50	
434266	___	Student Handouts	5.00	
412544	___	Facilitator Packet (Parent Guide)	10.00	

<b>Spelling (2nd ed.)</b>				
 517045	___	Student Worktext	29.25	
414060	___	Student Handouts	5.00	
413401	___	Facilitator Packet (Parent Guide)	10.00	



<b>Reading (3rd ed.)</b>				
 512996	___	Student Edition: Quests	68.00	44.20



Item #	Qty.	Description	Wholesale Price	Special Price
 513002	___	Activities	39.00	
513010	___	Activities Answer Key	39.00	
522755	___	<i>Misty of Chincoteague</i>	7.99	
522730	___	<i>Brady</i>	7.99	
522748	___	<i>The Horse and His Boy</i>	8.99	
452391	___	Student Handouts	5.00	
441881	___	Facilitator Packet (Parent Guide)	10.00	



<b>Handwriting (2nd ed.)</b>				
 271411	___	Student Worktext	25.00	
409011	___	Student Handouts	5.00	
412569	___	Facilitator Packet (Parent Guide)	10.00	

## Grade 6

<b>Bible (4th ed.)</b>				
 295279	___	Student Worktext	31.00	
257261	___	<i>Forbidden Gates</i> , Williamson	8.09	
434332	___	Student Handouts	5.00	
407858	___	Facilitator Packet (Parent Guide)	10.00	

<b>Science (4th ed.)</b>				
 522391	___	Student Edition	51.00	33.15
 281329	___	Activities	34.50	
434399	___	Student Handouts	5.00	
407973	___	Facilitator Packet (Parent Guide)	10.00	

<b>Heritage Studies (3rd ed.)</b>				
 522995	___	Student Edition	47.00	30.55
 233429	___	Activities	32.75	
434357	___	Student Handouts	5.00	
407890	___	Facilitator Packet (Parent Guide)	10.00	

<b>Math (4th ed.) <b>NEW!</b></b>				
 525444	___	Student Edition	64.75	42.09
 457218	___	Student Handouts	5.00	
457226	___	Facilitator Packet (Parent Guide)	10.00	

<b>English (2nd ed.)</b>				
 281576	___	Student Worktext	32.50	
434340	___	Student Handouts	5.00	
407874	___	Facilitator Packet (Parent Guide)	10.00	

<b>Spelling (2nd ed.)</b>				
 522417	___	Student Worktext	29.25	
434407	___	Student Handouts	5.00	
407999	___	Facilitator Packet (Parent Guide)	10.00	

<b>Reading (3rd ed.) <b>NEW!</b></b>				
 520320	___	Student Edition	68.00	44.20
520338	___	Student Activities	39.00	
520346	___	Activities Answer Key	39.00	
534719	___	<i>The Book of Three</i>	7.99	
534727	___	<i>A Single Shard</i>	8.99	
534735	___	<i>Island of the Blue Dolphins</i>	8.99	

Teacher editions and eTextbooks for Christian Classroom Online are available upon request. Please contact your Precept sales representative or call Customer Service at 800.845.5731.

Name \_\_\_\_\_

Account No. \_\_\_\_\_

When faxing or mailing your order, be sure to include page 98.

# Christian Classroom Online Order Form

Item #	Qty.	Description	Wholesale Price	Special Price
454256	___	Student Handouts	5.00	
454314	___	Facilitator Packet (Parent Guide)	10.00	
<b>Handwriting (2nd ed.)</b>				
 271429	___	Student Worktext	25.00	
029314	___	Calligraphy Pen (Sanford)	2.26	
434365	___	Student Handouts	5.00	
407916	___	Facilitator Packet (Parent Guide)	10.00	

## Grade 7

### Bible (1st ed.)

 512210	___	Student Edition	29.25	19.01
512228	___	Activities	24.25	
446872	___	Student Handouts	5.00	
446989	___	Facilitator Packet (Parent Guide)	10.00	

### Life Science (5th ed.) **NEW!**

 513051	___	Student Edition	77.50	50.38
513077	___	Activities	34.50	
513069	___	Activities Answer Key	40.00	
457655	___	Student Handouts	5.00	
457663	___	Facilitator Packet (Parent Guide)	10.00	

### World Studies (4th ed.)

 515874	___	Student Edition	69.50	45.18
501726	___	Activities	38.00	
501734	___	Activities Answer Key	43.00	
434449	___	Student Handouts	5.00	
428656	___	Facilitator Packet (Parent Guide)	10.00	

### Fundamentals of Math (2nd ed.)

 515882	___	Student Edition	64.75	42.09
434456	___	Student Handouts	5.00	
428664	___	Facilitator Packet (Parent Guide)	10.00	

### English (4th ed.)

 520056	___	Student Edition (Literature)	68.00	44.20
518514	___	Student Worktext (W&G)	35.75	
526087	___	<i>The Last Battle</i>	10.99	
446880	___	Student Handouts	5.00	
446997	___	Facilitator Packet (Parent Guide)	10.00	

## Grade 8

### Bible (1st ed.)

 514596	___	Student Edition	29.25	
454264	___	Student Handouts	5.00	
454322	___	Facilitator Packet (Parent Guide)	10.00	

### Earth Science (4th ed.)

 515718	___	Student Edition	77.50	50.38
---	-----	-----------------	-------	-------

Item #	Qty.	Description	Wholesale Price	Special Price
 271528	___	Lab Manual Teacher Edition	40.00	
271494	___	Student Lab Manual	34.50	
434514	___	Student Handouts	5.00	
429241	___	Facilitator Packet (Parent Guide)	10.00	

### American Republic (4th ed.)

 515841	___	Student Edition	69.50	45.18
298380	___	Activities	38.00	
298364	___	Activities Answer Key	43.00	
434506	___	Student Handouts	5.00	
412700	___	Facilitator Packet (Parent Guide)	10.00	

### Pre-Algebra (2nd ed.)

 517060	___	Student Edition	64.75	42.09
452326	___	Student Handouts	5.00	
428680	___	Facilitator Packet (Parent Guide)	10.00	

### English 8 (4th ed.)

 528893	___	Student Edition (Literature)	68.00	44.20
523092	___	Student Worktext (Writing & Grammar)	35.75	
538082	___	<i>Across Five Aprils</i>	7.99	
454272	___	Student Handouts	5.00	
454330	___	Facilitator Packet (Parent Guide)	10.00	

## Grade 9

### Bible

 290106	___	<i>Publish Great Things</i> Student Edition	13.75	
270819	___	<i>That I May Know Him</i> Student Edition	13.75	
290098	___	<i>Why the Bible Matters</i> Student Edition	13.75	
410423	___	Student Handouts	5.00	
412734	___	Facilitator Packet (Parent Guide)	10.00	

### Physical Science (6th ed.)

 515437	___	Student Edition	77.50	50.38
515494	___	Student Lab Manual	34.50	
515502	___	Teacher Lab Manual	40.00	
452409	___	Student Handouts	5.00	
441980	___	Facilitator Packet (Parent Guide)	10.00	

### Geography (5th ed.) **NEW!**

 518746	___	Student Edition	69.50	45.18
518761	___	Activities	38.00	
518779	___	Activities Answer Key	43.00	
446898	___	Student Handouts	5.00	
447003	___	Facilitator Packet (Parent Guide)	10.00	

### Algebra 1 (4th ed.) **NEW!**

 537076	___	Student Edition	64.75	42.09
458281	___	Student Handouts	5.00	
458299	___	Facilitator Packet (Parent Guide)	10.00	

Teacher editions and eTextbooks for Christian Classroom Online are available upon request. Please contact your Precept sales representative or call Customer Service at 800.845.5731.

# Christian Classroom Online Order Form

Name \_\_\_\_\_

Account No. \_\_\_\_\_

When faxing or mailing your order, be sure to include page 98.

Item #	Qty.	Description	Wholesale Price	Special Price
<b>Writing &amp; Grammar 9 (3rd ed.)</b>				
 281667	___	Student Worktext	35.75	
434530	___	Student Handouts	5.00	
412742	___	Facilitator Packet (Parent Guide)	10.00	

<b>Fundamentals of Literature (2nd ed.)</b>				
 514042	___	Student Edition	68.00	44.20
412148	___	Student Handouts	5.00	
412759	___	Facilitator Packet (Parent Guide)	10.00	

## Grade 10

<b>Bible 10 Doctrines for a Biblical Worldview (1st ed.) <span style="background-color: green; color: white; padding: 2px;">NEW!</span></b>				
 521914	___	Student Edition	29.25	
521948	___	Activities	24.25	
521955	___	Activities Answer Key	20.50	
458141	___	Student Handouts	5.00	
458158	___	Facilitator Packet (Parent Guide)	10.00	

<b>Biology (4th ed.)</b>				
 268078	___	Student Edition	77.50	50.38
268094	___	Student Lab Manual	34.50	
268169	___	Lab Manual Teacher Edition	40.00	
413419	___	Student Handouts	5.00	
412833	___	Facilitator Packet (Parent Guide)	10.00	

<b>World History (5th ed.)</b>				
 512293	___	Student Edition	69.50	45.18
512723	___	Activities	38.00	
512731	___	Activities Answer Key	43.00	
442095	___	Student Handouts	5.00	
442087	___	Facilitator Packet (Parent Guide)	10.00	

<b>Geometry (4th ed.)</b>				
 515858	___	Student Edition	64.75	42.09
420398	___	Student Handouts	5.00	
420380	___	Facilitator Packet (Parent Guide)	10.00	

<b>Writing &amp; Grammar 10 (4th ed.)</b>				
 522458	___	Student Worktext	35.75	
434597	___	Student Handouts	5.00	
413443	___	Facilitator Packet (Parent Guide)	10.00	

<b>Elements of Literature (2nd ed.)</b>				
 517029	___	Student Edition	68.00	44.20
434605	___	Student Handouts	5.00	
413450	___	Facilitator Packet (Parent Guide)	10.00	

## Grade 11

<b>Bible</b>				
 271759	___	<i>Beyond the Sun</i> Student Edition	13.75	
290080	___	<i>The Way of the Word</i> Student Edition	13.75	
271783	___	<i>What Is Truth?</i> Student Edition	13.75	

Item #	Qty.	Description	Wholesale Price	Special Price
415620	___	Student Handouts	5.00	
412841	___	Facilitator Packet (Parent Guide)	10.00	

<b>Chemistry (5th ed.)</b>				
 519751	___	Student Edition	77.50	50.38
519777	___	Student Lab Manual	34.50	
519785	___	Lab Manual Teacher Edition	40.00	
446906	___	Student Handouts	5.00	
447011	___	Facilitator Packet (Parent Guide)	10.00	

<b>United States History (5th ed.)</b>				
 505776	___	Student Edition	69.50	45.18
506675	___	Activities	38.00	
506683	___	Activities Answer Key	43.00	
452334	___	Student Handouts	5.00	
428706	___	Facilitator Packet (Parent Guide)	10.00	

<b>Algebra 2 (3rd ed.)</b>				
 536995	___	Student Edition	64.75	41.93
414128	___	Student Handouts	5.00	
433821	___	Facilitator Packet (Parent Guide)	10.00	

<b>English 11 (3rd ed.)</b>				
 536557	___	Student Edition (Literature)	68.00	44.20
514067	___	Student Worktext (Writing & Grammar)	35.75	
452425	___	Student Handouts	5.00	
442186	___	Facilitator Packet (Parent Guide)	10.00	

## Grade 12

<b>Bible</b>				
 296780	___	<i>God and His Ways</i> Student Edition	13.75	
278051	___	<i>How Firm a Foundation!</i> Student Edition	13.75	
512194	___	<i>In God's Presence</i> Student Edition	13.75	
434696	___	Student Handouts	5.00	
412908	___	Facilitator Packet (Parent Guide)	10.00	

<b>Physics (3rd ed.)</b>				
 523084	___	Student Edition	77.50	50.38
259077	___	Student Lab Manual	34.50	
259093	___	Lab Manual Teacher Edition	40.00	
434746	___	Student Handouts	5.00	
433896	___	Facilitator Packet (Parent Guide)	10.00	

<b>American Government (4th ed.) <span style="background-color: green; color: white; padding: 2px;">NEW!</span></b>				
 513523	___	Student Edition	61.75	40.14
516518	___	Activities	35.75	
516559	___	Activities Answer Key	43.00	
457952	___	Student Handouts	5.00	
433854	___	Facilitator Packet (Parent Guide)	10.00	

<b>Economics (3rd ed.)</b>				
 517086	___	Student Edition	61.75	40.14

Teacher editions and eTextbooks for Christian Classroom Online are available upon request. Please contact your Precept sales representative or call Customer Service at 800.845.5731.















Name \_\_\_\_\_

Account No. \_\_\_\_\_

When faxing or mailing your order, be sure to include page 98.

# Christian Classroom Online

## Order Form

Item #	Qty.	Description	Wholesale Price	Special Price
 500561	___	Activities	35.75	
500579	___	Activities Answer Key	43.00	
434738	___	Student Handouts	5.00	
433888	___	Facilitator Packet (Parent Guide)	10.00	
<b>Precalculus (2nd ed.)</b>				
 299974	___	Student Edition	64.75	42.09
 452342	___	Student Handouts	5.00	
452219	___	Facilitator Packet (Parent Guide)	10.00	
<b>Writing &amp; Grammar 12 (2nd ed.)</b>				
 194837	___	Student Worktext	35.75	
434704	___	Student Handouts	5.00	
433854	___	Facilitator Packet (Parent Guide)	10.00	
<b>British Literature (2nd ed. Updated Version)</b>				
 515767	___	Student Edition	68.00	44.20
 434712	___	Student Handouts	5.00	
433862	___	Facilitator Packet (Parent Guide)	10.00	
<b>Grades 11–12 Consumer Math (3rd ed.)</b>				
 518597	___	Student Edition	64.75	
446914	___	Student Handouts	5.00	
447029	___	Facilitator Packet (Parent Guide)	10.00	
<b>Modern Language</b>				
<b>Spanish 1 (2nd ed.)</b>				
 517979	___	Spanish 1 Student Edition	61.75	40.14
 194571	___	Activities	32.50	
194589	___	Activities Answer Key	35.75	
533067	___	Spanish/English Dictionary (Merriam-Webster)	7.50	
434779	___	Student Handouts	5.00	
413005	___	Facilitator Packet (Parent Guide)	10.00	
<b>Spanish 2 (2nd ed.)</b>				
 515817	___	Student Edition (Grades 9–12)	61.75	40.14
 189548	___	Activities	32.50	
189555	___	Activities Answer Key	35.75	
533067	___	Spanish/English Dictionary (Merriam-Webster)	7.50	
434787	___	Student Handouts	5.00	
413476	___	Facilitator Packet (Parent Guide)	10.00	
<b>Spanish 3 (1st ed.)</b>				
 281642	___	Student Edition	61.75	40.14
 182923	___	Activities	32.50	
182931	___	Activities Answer Key	35.75	
533067	___	Spanish/English Dictionary (Merriam-Webster)	7.50	
452359	___	Student Handouts	5.00	
452227	___	Facilitator Packet (Parent Guide)	10.00	
<b>American Sign Language (only available for Option 2)</b>				
442251	___	Student Handouts	5.00	

Teacher editions and eTextbooks for Christian Classroom Online are available upon request. Please contact your Precept sales representative or call Customer Service at 800.845.5731.

# THE exchange CONFERENCE



## **Annual Professional Development**

Join us every July in Greenville, South Carolina, to exchange ideas and support your fellow educators!

- »» Continuing education units
- »» Over 80 in-person sessions & over 30 virtual sessions
- »» Early bird discount available

Visit [bjupress.com/exchange](https://bjupress.com/exchange) for more details!

**We long to see the next generation  
prepared to be salt and light in  
positions of leadership and influence  
in society. BJU Press is dedicated to  
publishing academically rigorous  
textbooks written from a biblical  
worldview to support Christian  
educators who share our goal.**





1430 Wade Hampton Blvd.  
Greenville, SC 29609

CHANGE SERVICE REQUESTED

PRST STD  
U.S. Postage  
PAID  
Greenville, SC  
Permit No. 625



# Teacher Edition podcast

Where Christian educators are encouraged and inspired, as we bring you interviews, practical ideas, strategies, and answers to your questions about teaching in today's culture.

Scan to subscribe



Available now on all podcast platforms